

# MicroPak™

Electronic Instrument Enclosures  
for Small Free-standing and Hand-held Applications



LANSING

---

## The MicroPak™ Enclosure Design Concept

Lansing MicroPak Electronic Enclosures offer significant value in a smaller, free-standing enclosure, including design and engineering elements typical of fine custom-made products – without the high cost and lead time of custom fabrication.

The premise behind the design is a simple one: Create a tube using one or two pieces. Seal the ends of the tube from a selection of possible end configurations. Provide a convenient way to mount printed circuit boards and interface other electronics. Provide a quality finish suitable for the finest of products. Do this at a reasonable price.

In the following pages, you'll see that attention has been paid to even the small details to ensure a design of the highest quality, and a finished product you can be proud of.

## The MicroPak Advantages...

**Save you time.** Their proven, pretested designs deliver ready-to-use reliable performance, reducing the lead time and prototyping problems associated with designing from scratch. Using MicroPak Enclosures also simplifies the transition from prototype to full production. And they're designed for fast, efficient board mounting and assembly.

**Save you money.** Low-volume buyers benefit from our economical, established designs and proven performance. High-volume buyers save even more. Whichever the case, we'll work with you to achieve the solution that's most economical for you – one that takes into account not only the initial price of the enclosure, but related production costs as well.

**Meet your specific requirements.** MicroPaks are designed to make the addition of your product details fast and economical throughout prototyping and production – whether we do it for you, or you do it yourself.

**Add value to your product.** Sturdy, carefully engineered design and quality construction provide maximum protection for your electronics. And best of all, MicroPak Enclosures give your product a solid, precision-manufactured look and feel that tells your customers – in a way facts and figures never can – that yours is a quality instrument.

**Reflect your product's unique personality.** MicroPak's basic designs are simple and unobtrusive. It's your choice of style, options, finish, custom machining and graphics that determines your product's personality. MicroPak offers three distinct styles, many sizes and configurations, and a variety of finishes and options. Customizing is also available. The result is an enclosure that becomes as much a part of your product as a custom fabrication.

**Accommodate your growing product line.** MicroPak provides a comprehensive enclosure family – complementary in appearance and construction – to make future product changes simple and economical. And as you add new products to your line, the look you've already established can be maintained (both within the same style and across styles), minimizing the need for additional development costs and building on the equity of your earlier product.

**Get to you fast.** We keep a range of standard enclosure sizes in stock for immediate shipment anywhere in the world. And our personal attention ensures that even customized enclosures are shipped in a minimum of time – generally less than 15 to 23 working days.

## We Want to Make You a No-Risk Offer.

There's no substitute for having the "real thing" in your hands. That's why we offer our new customers the opportunity to obtain one or more MicroPak Enclosures at special prices. Details can be found under the back flap.

# MicroPak Enclosures Index

Choosing a MicroPak style that meets your size, panel, printed circuit board and access requirements.

- **C Style MicroPak — Pages 4-9**  
Our original economical design with extruded base and formed, slide-on cover.

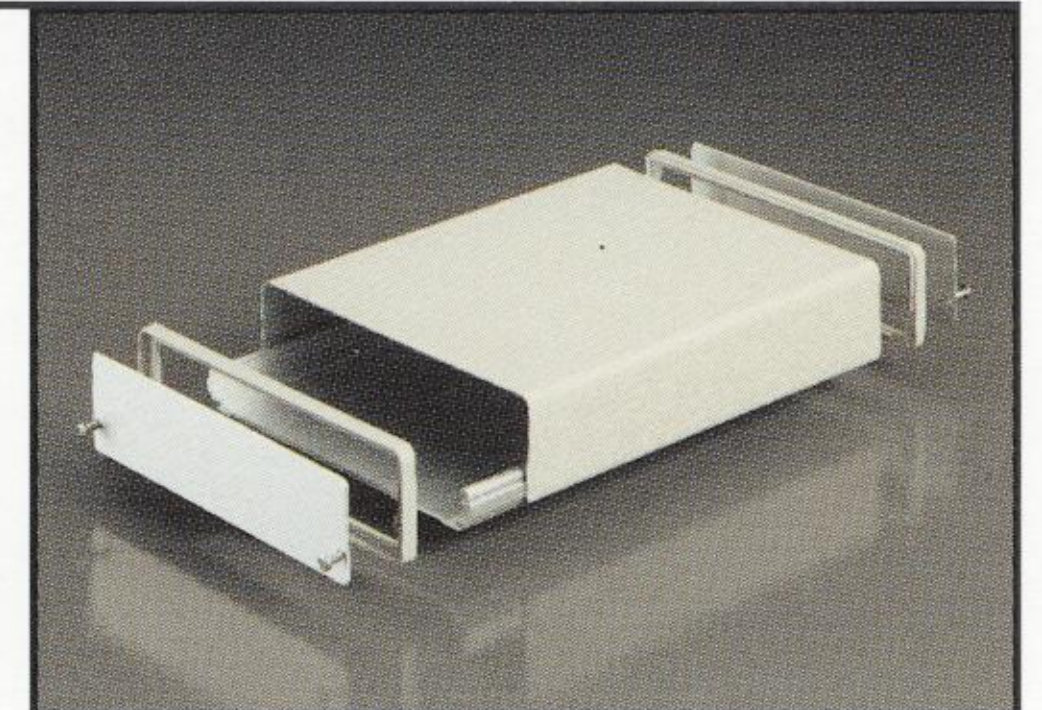

- **D Style MicroPak — Pages 10-13**  
Our simplest design using a one-piece, seamless extruded tube.

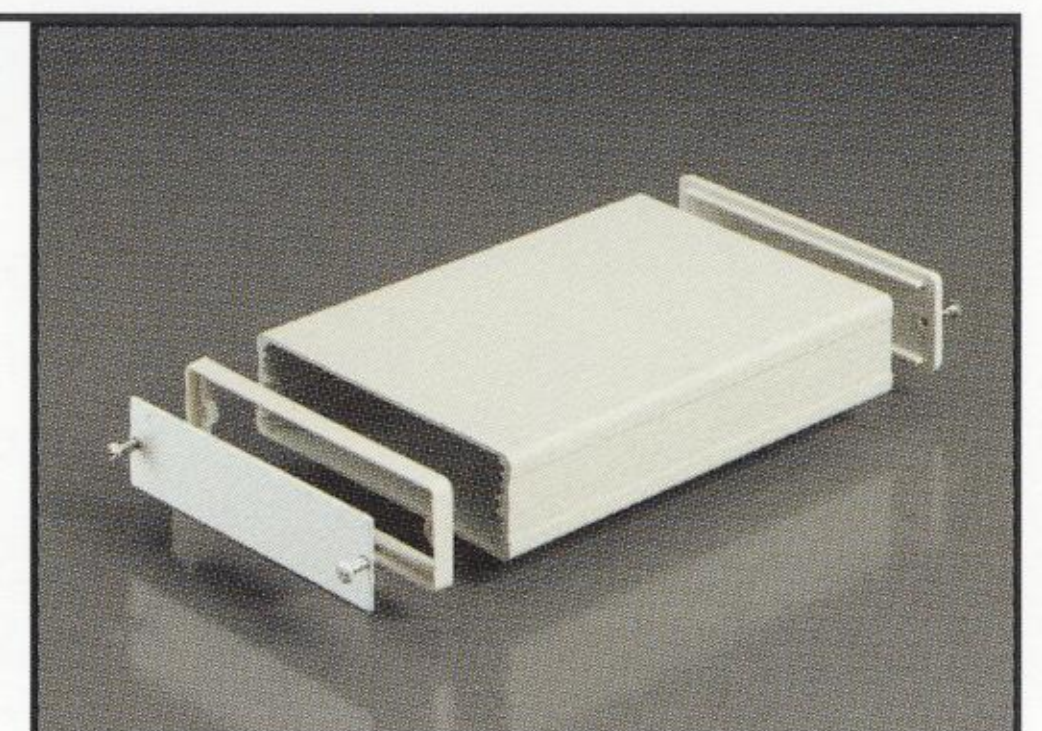

- **E Style MicroPak — Pages 14-17**  
An optimized design for maximum control-panel area with extruded base and slide-in flat panel.

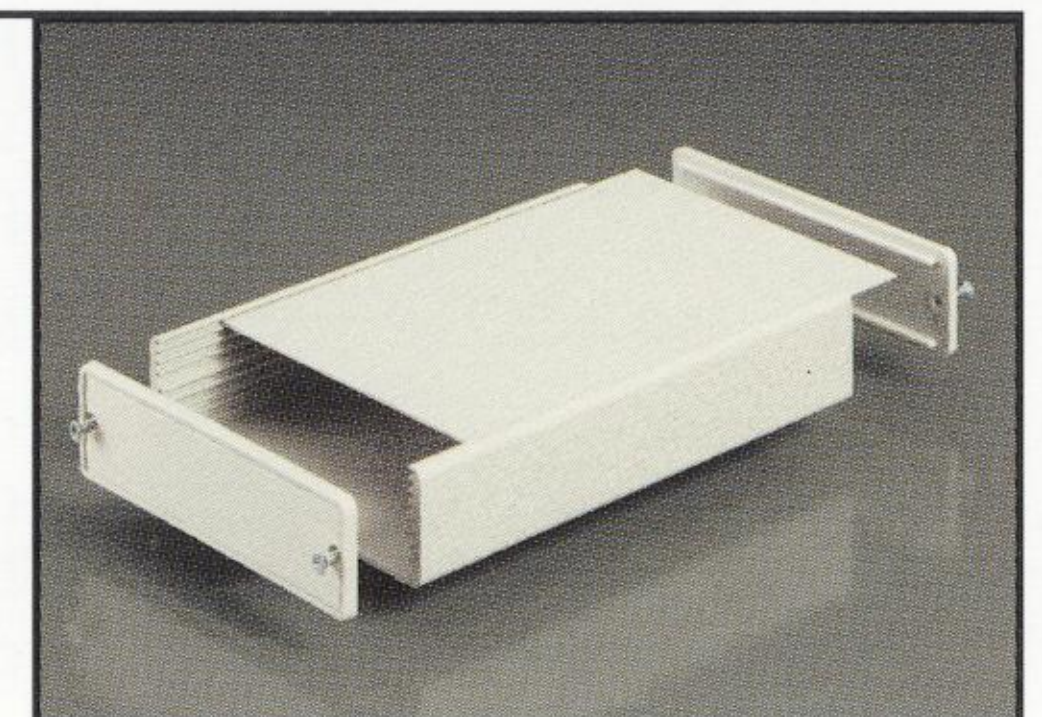

**Rack Mount Panels — Pages 18-19**

Finishing the job...  
Making a MicroPak part of your product

- **Customization — Pages 20-21**  
Level 1: Special sizes, machining and graphics.  
Level 2: Higher level customization.



**Technical Support — Page 22**

**Technical Literature — Under Back Flap**  
Specifications, engineering drawings and other technical details for each MicroPak style.

**Price List — Under Back Flap**  
Prices, order form and sample offer.

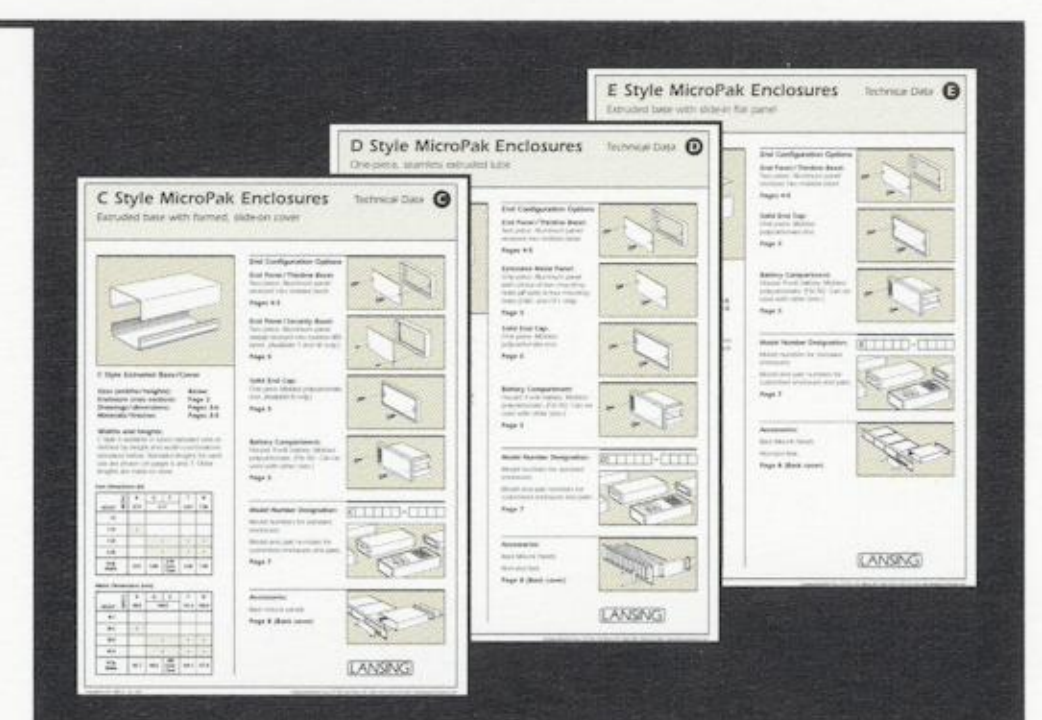

**Doing business with Lansing — Page 23**



# C Style MicroPak Enclosures

## Our original economical design with extruded base and formed, slide-on cover

The C Style MicroPak is our original design and most economical of the three styles. Ideal for small desk top and/or hand-held instruments

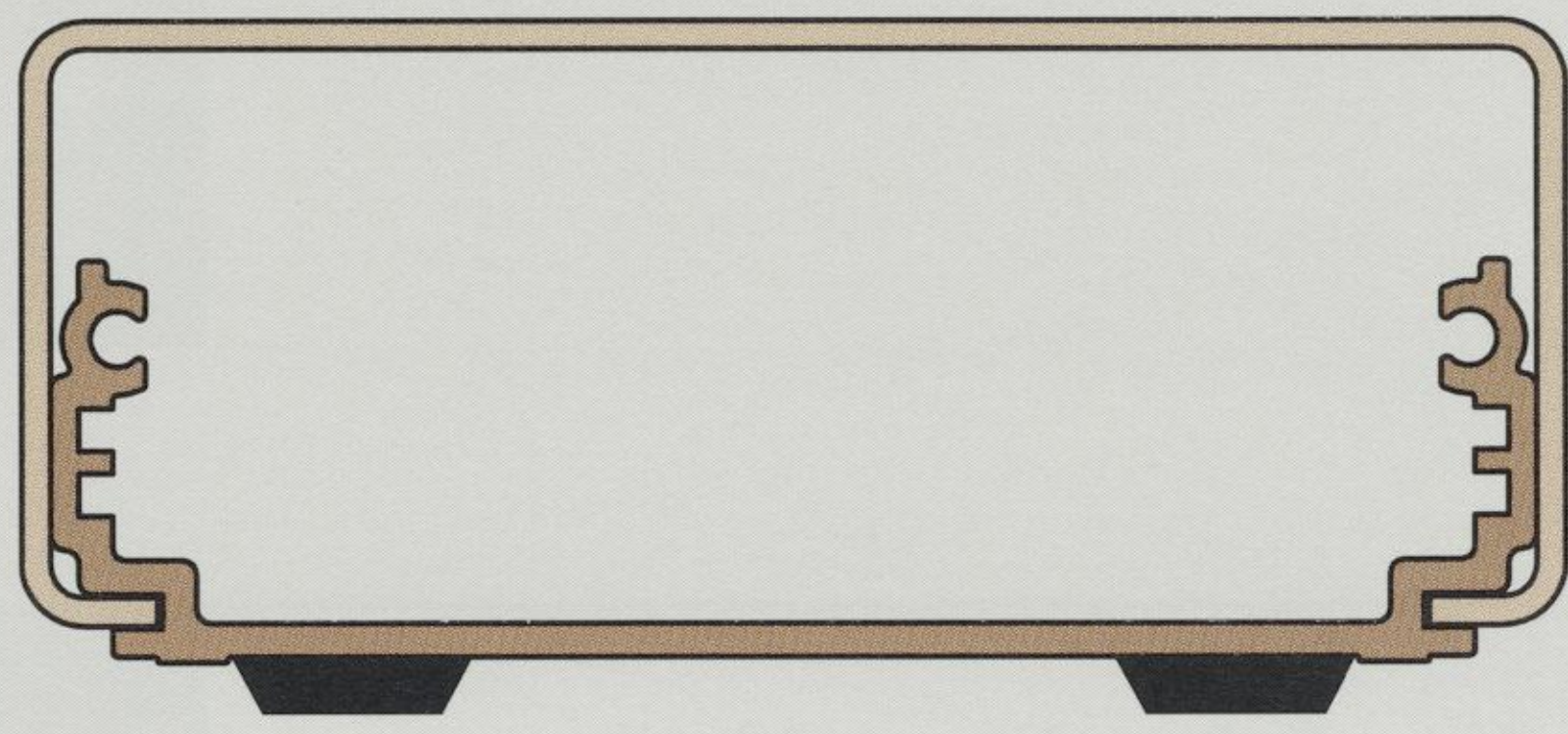

*C Style MicroPak Enclosures, shown here in typical cross-section, are characterized by a tubular body consisting of a rugged extruded base and a formed slide-on cover. The base contains one or more tracks for printed circuit boards. The removable cover permits easy access to the interior.*

### Remember the MicroPak Advantages...

- Proven designs save you both development and production time.
- Reasonable pricing at any quantity saves you money.
- Flexible design readily adapts to your specific requirements.
- Quality construction and attractive appearance add value to your product.
- Simple, unobtrusive design allows your product to take on its own unique personality.
- Extensive range of sizes accommodates your growing product line.
- We get it to you fast.

For the full story, please read the inside front cover.

requiring limited front and rear panel space, its rugged body construction incorporates an extruded base and a formed, slide-on cover.

Select from a variety of **end configurations**. Since C Style is designed principally to use the two ends as control panels, the two-piece end panel/bezel combination is a frequent choice. Some sizes offer a selection of bezel styles, a solid end cap and a battery compartment.

**Bottom details** include standard non-skid feet and a recessed area for product labeling.

MicroPak Enclosures are available in a contemporary palette of **colors** in both warm and cool color families.

The C Style **family** has 18 standard sizes (three heights, four widths and a variety of standard lengths) available from stock. We can make almost any length to order.

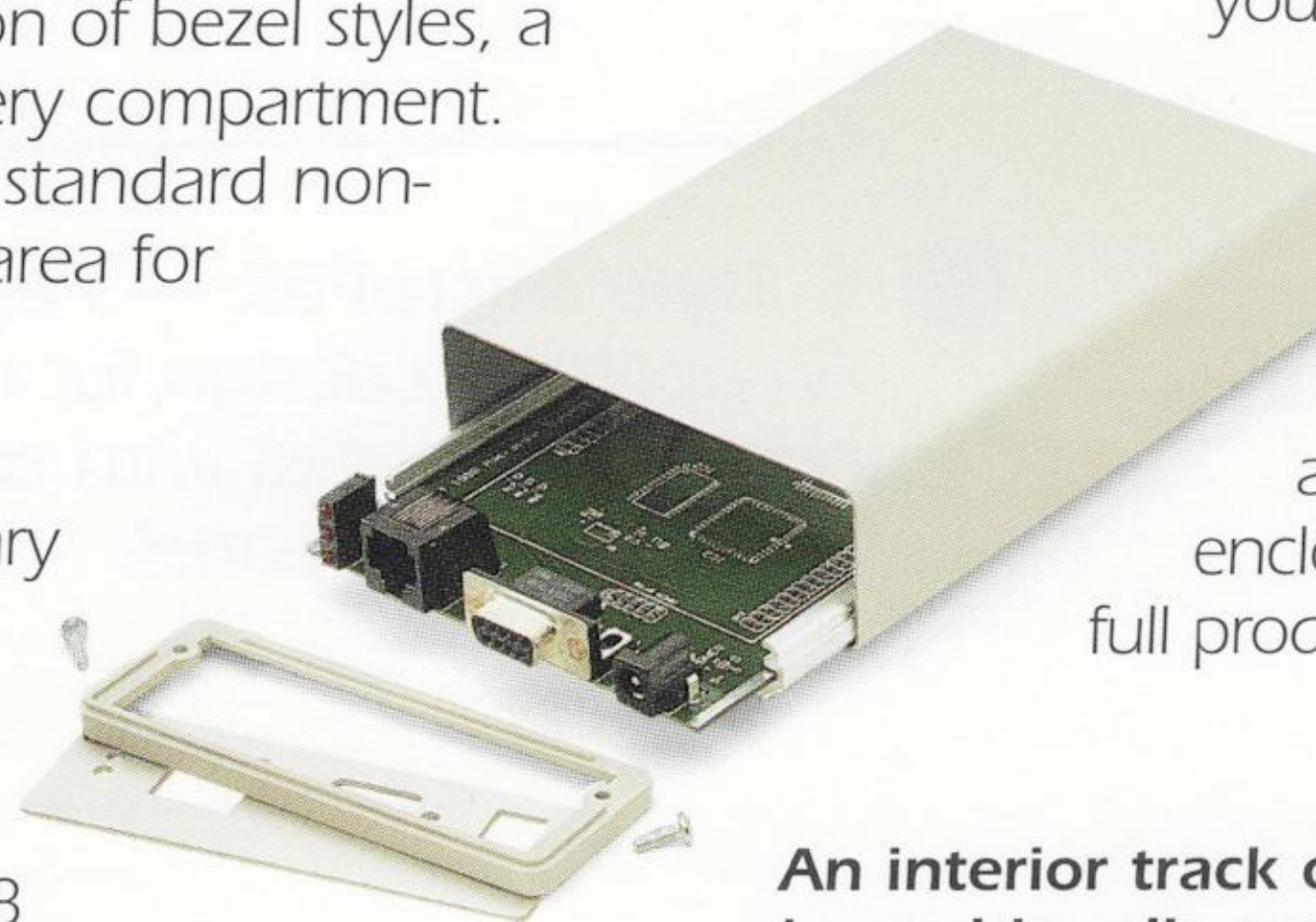

Each enclosure has at least one set of tracks for **mounting printed circuit boards**. These tracks provide an efficient and secure way to hold your board during assembly, testing and in the completed product. Alternatively, boards may be mounted on standoffs.

The standard C Style Enclosure has **shielding** characteristics suitable for most applications. For more demanding requirements, optional enhancements are available.

C Style can be mounted in a standard 19-inch rack using a **MicroPak Rack Mount Panel**.

MicroPak Enclosures can take on a function and personality that is all yours. Whether it be machining or graphics, our experienced staff can provide the **customizing** details you need and deliver quality, ready-to-use enclosures at a reasonable cost.

At Lansing, **technical support** is part of the product. It's our philosophy of working with you to arrive at the optimum packaging solution for your product at the best final price to you. We'll work hard to help you turn your concept into a reality whether for one enclosure, an initial prototype or full production.

**An interior track on the extruded base side rails provides a convenient way to mount a PCB during assembly and in the finished product.**

## C Style Family

N-Width	Q-Width	T-Width	W-Width	
				.75 in (19.1 mm)
				1.12 in (28.5 mm)
				1.52 in (38.6 mm)
				2.52 in (64.0 mm)
2.75 in (69.8 mm)	4.17 in (106.0 mm)	5.57 in (141.4 mm)	7.29 in (185.0 mm)	
5.00 (127.0) 6.00 (152.4)	5.00 (127.0) 6.00 (152.4) 6.30 (160.0)*	5.00 (127.0) 6.00 (152.4) 7.00 (177.8) 8.50 (215.9)	9.00 (228.6)	Standard (stocked) lengths – inch (metric)

\*Accepts 100 mm x 160 mm Eurocards.

Other lengths are made to order.

### C Style Widths and Heights

The entire MicroPak family (consisting of C, D and E Styles) is available in ten standard sizes defined by the height and width combinations displayed on the right.

The C Style is available in the seven sizes indicated. Within each size there are one or more standard lengths (front to back) available from stock. These standard lengths are tabulated at the bottom of each column to the right. Lengths other than these are made to order.

Note that enclosure length is defined as length of cover and base. Overall length depends on the end configurations chosen. Refer to the C Style Technical Data Sheet.

**Clean Styling** blends with modern computer equipment designs.

**Fast, Efficient Assembly** – Typically six parts plus four screws.

**Heavy-Duty Vinyl-Clad Steel Cover** provides durability and a solid feel.

**Extruded Aluminum Base** serves as a rugged frame for the enclosure.

**End Panel/Bezel** – One of three interchangeable end configurations.

**Printed Circuit Board Track** holds board securely during assembly/testing and in completed instrument.

**Precision Interchangeable Parts** have close mechanical tolerances.

**EMI Shielding** is sufficient for most applications. Enhanced shielding is available for more stringent applications.

**MicroPak Enclosures accommodate your growing product line** by providing a comprehensive family of enclosures with complementary appearance and construction across all styles (C, D and E). The C Style, characterized by a formed cover that slides onto an extruded base, is available in both standard and nonstandard sizes. There are 18 standard sizes in stock – all available in Lansing's full palette of colors. Nonstandard sizes are made to order.

Your first MicroPak will demonstrate how accommodating its design can be, how simply and quickly one can go from prototype to production and how much it can enhance the presentation of your product. And as you add new products to your line, the look you've already established can be maintained (both within the C Style and across styles), minimizing the need for additional development costs and building on the equity of your earlier product.



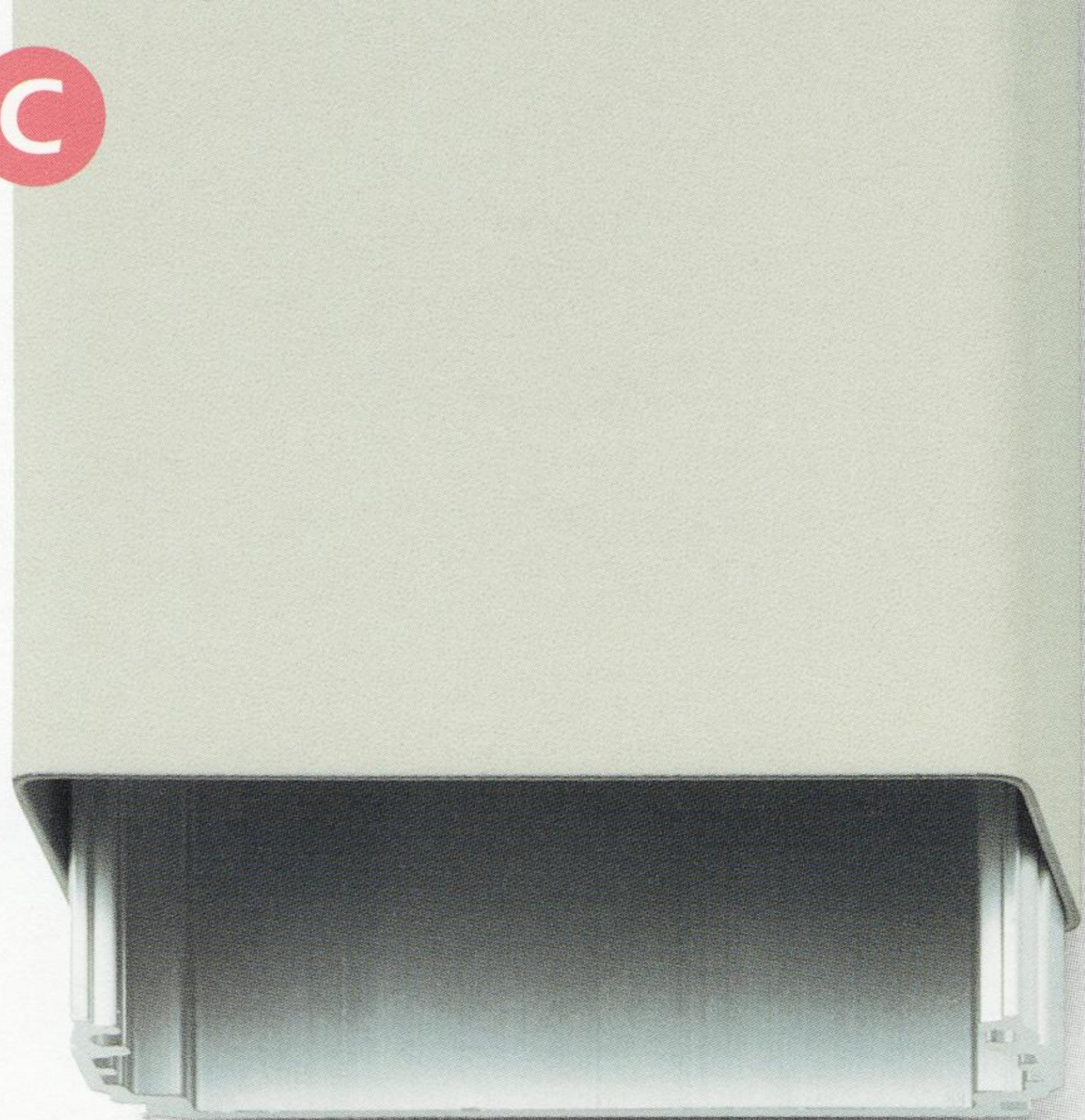

**N-width extruded base with formed slide-on cover.** (N2 shown actual size)



**End Panel/Thinline Bezel.** Available with pan head or flat head screws. Easy to machine. Ideally suited for silkscreening or overlays.



**Solid End Cap.** Available with flat head screws. Can be machined. Designed to accept an overlay.



**Battery Compartment.** 9-volt battery housing with convenient sliding access cover. Fits N2 enclosures. Can also be mounted in any Q-, T- and W-width enclosures.

## C Style End Configurations

Each end of a C Style MicroPak Enclosure can be fitted with an **end panel/bezel** combination, a **solid end cap** or a **battery compartment**.

The **end panel/bezel** combination is the most versatile option and is available on all sizes. The end panel is a flat metal plate that recesses into and is framed by the molded plastic bezel. It comes in a variety of finishes and is available for use with pan head or flat head screws. Holes, inserts and/or silkscreening are easily added, making it well suited for customization. Overlays are particularly suitable, since all edges are protected by the bezel.

Two styles of bezel exist – thinline and security. The **thinline bezel** mounts flush with cover and base, providing a streamlined appearance. It has a recess of 0.125 in (3.2 mm) that frames and protects the edges of the end panel. The **security bezel** (available on T- and W-widths only) encapsulates cover and base to produce a more “secure” enclosure for harsher applications or simply to provide a different appearance. It has a deeper recess, 0.340 in (8.64 mm), that helps protect panel components. Both styles of bezel are interchangeable and can be used with the same end panel. Both may be used on the same enclosure with the security bezel clearly identifying the front of the instrument. Standard bezels are molded in ABS except for N-width (molded in polycarbonate).

The solid **end cap** (available on N-width only), the simplest end configuration, is molded in durable polycarbonate. It is used with flat head screws and can be customized by milling or drilling. It has a shallow recess designed to accept an overlay.

The **battery compartment**, also molded in durable polycarbonate, houses a 9-volt battery. Access to the compartment is through a sliding cover that snaps conveniently and securely into position. It specifically fits the N2 size but may be used with any larger MicroPak Enclosure as an insert in an end panel, base or cover.

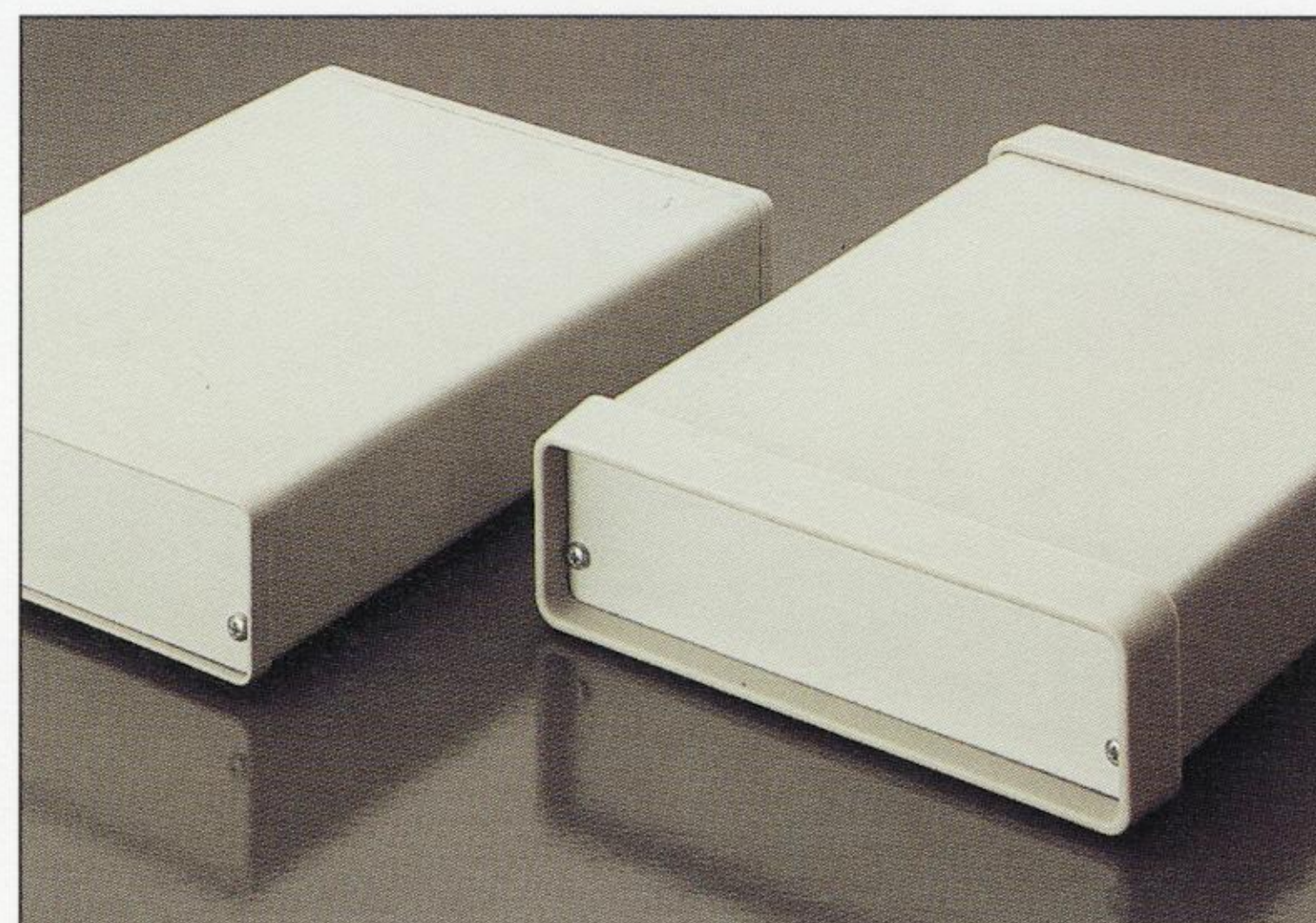

**Thinline and security bezels.** Two identical enclosures assembled with thinline bezels (left) and security bezels (right) demonstrate the difference in the two styles.



**Phillips Pan or Phillips Flat Head Screw Choices** (shown actual size) – Available in silver or black. Note: If you select flat head screws, the screw holes in the end panel will be countersunk.



**Q-, T- or W-width extruded base with formed slide-on cover.**  
(T1 shown actual size)

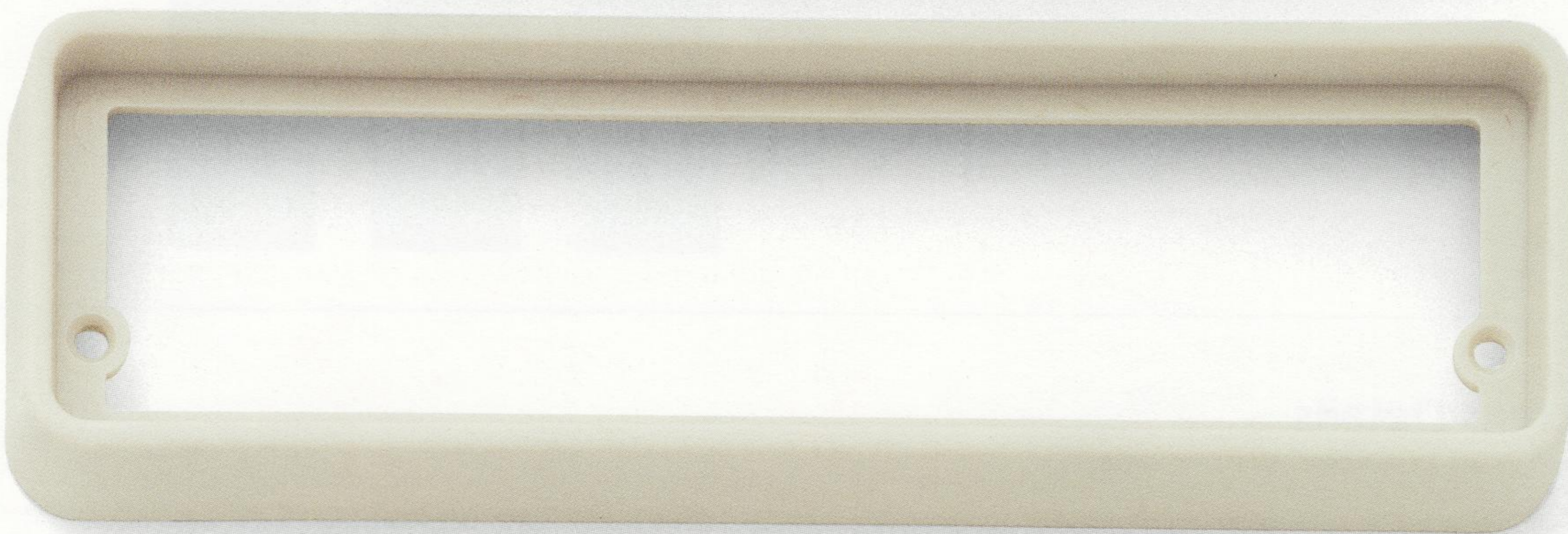

**Security Bezel** (available on T- and W-widths only) is deeply recessed and encapsulates cover and base, producing a particularly "secure" enclosure (cross-section view shown to the right). It is interchangeable with the thinline bezel shown below.

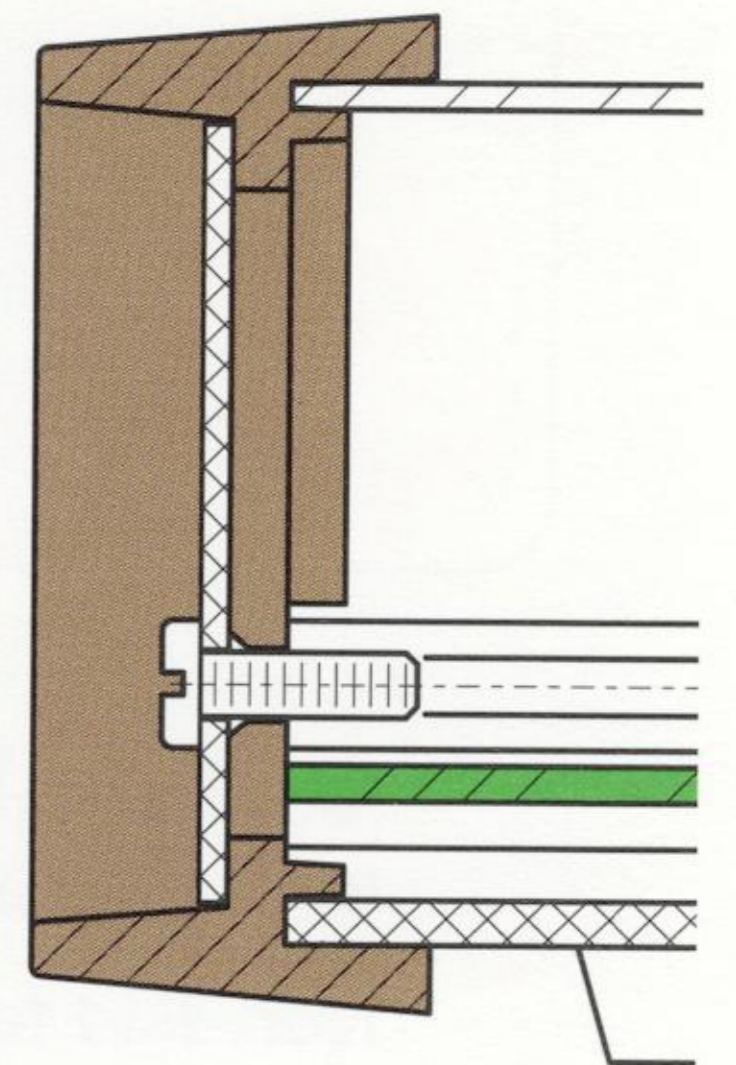

**Security Bezel  
Cross-section Detail**



**Thinline Bezel** has modest recess and is flush with cover and base, providing a streamlined appearance (cross-section view shown to the right). It is interchangeable with the security bezel shown above.

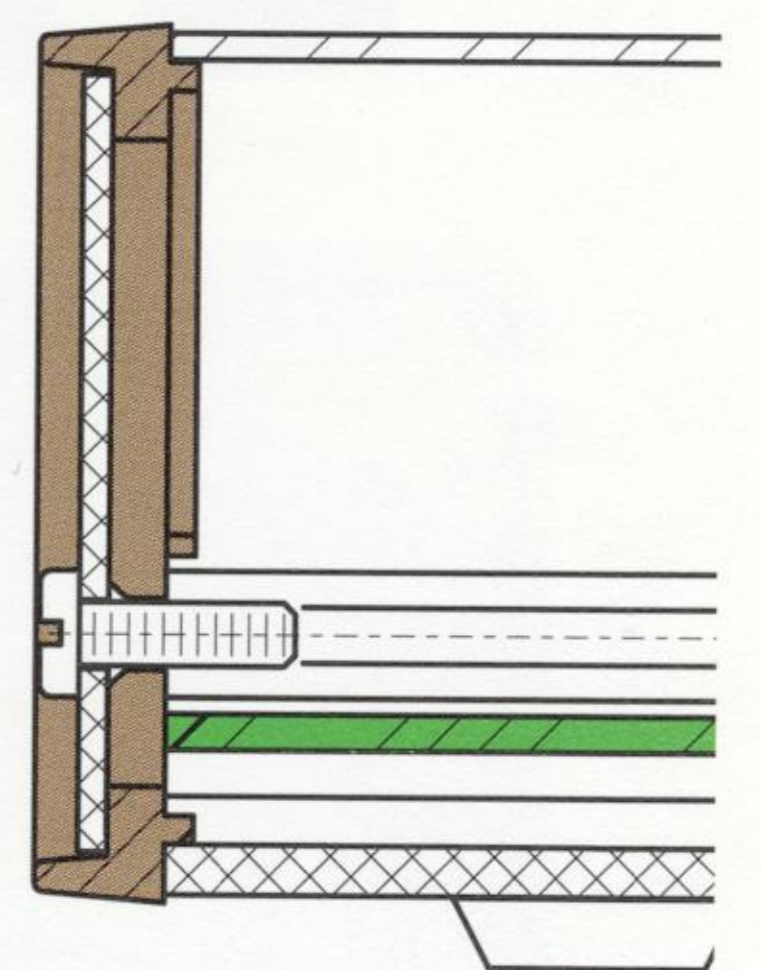

**Thinline Bezel  
Cross-section Detail**



**End Panel.** Available with pan head or flat head screws. Easy to machine. Ideally suited for silkscreening or overlays. May be used interchangeably with either the thinline or security bezels shown above.

## C Style Color Choices

(shown 50% actual size)

MicroPak Enclosures are available in a contemporary palette of colors comprised of two color families – a warm family that is IBM compatible and a cool family, including some that are Apple compatible. To create the perfect color scheme for your finished product, choose from the options shown on the right.

Mix or match bezel/end cap and cover colors bearing in mind that your choices of panel finish, graphics, screw type and screw color also contribute to the overall final appearance. The charts should be regarded as a relative rather than an absolute representation of color. Actual color chips are available on request.

**Custom colors** are available. Refer to the Customization section on pages 20-21.

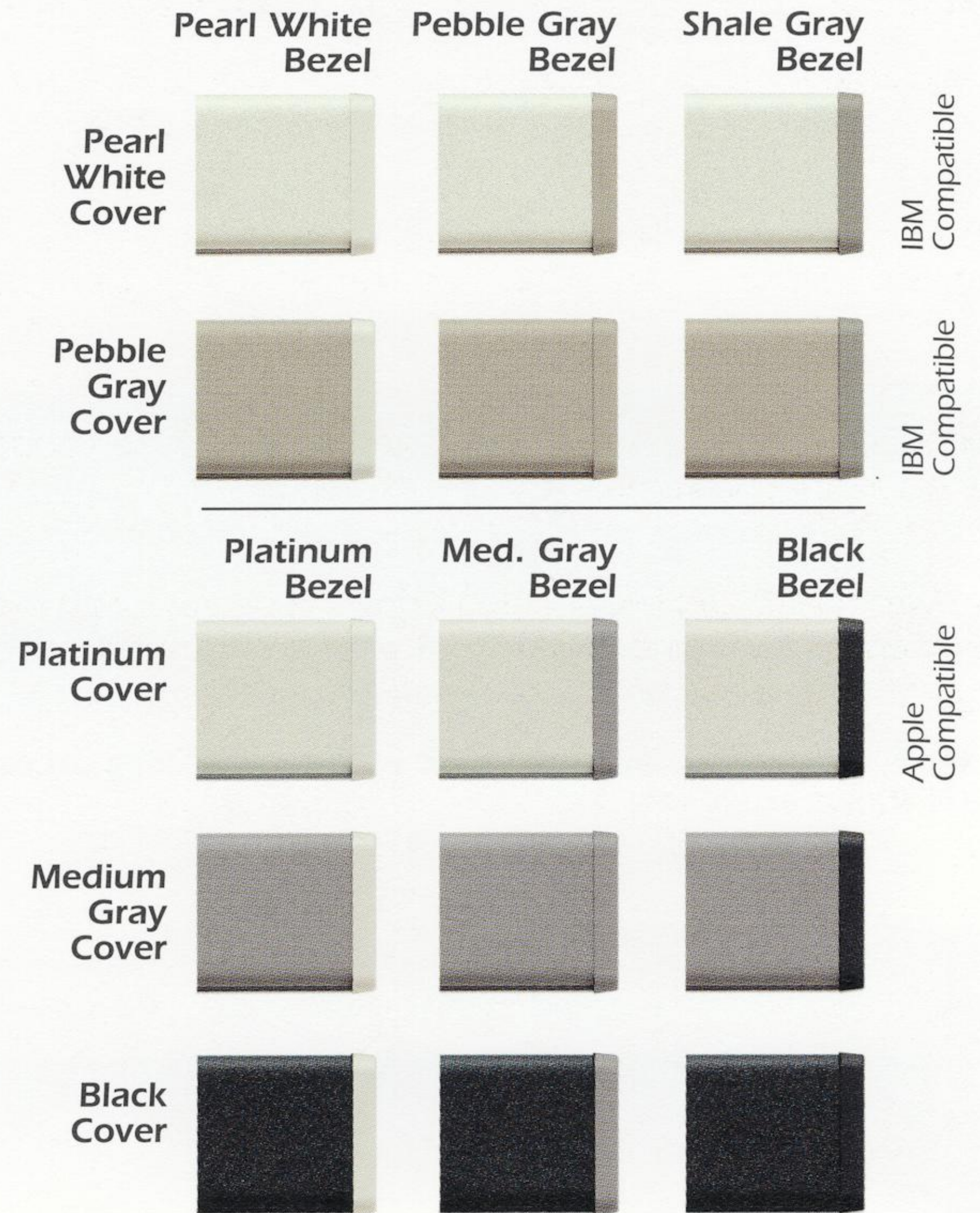

## C Style Bottom Details

(shown actual size on an assembled W1 enclosure)

**Non-skid feet** that prevent the unit from sliding on flat surfaces are standard on every C Style Enclosure and are applied to the base prior to shipping. The sizes used on each width are shown below. Most C Style Enclosures (N-width excluded) have a **recessed area** on the bottom surface that is suitable for labels.

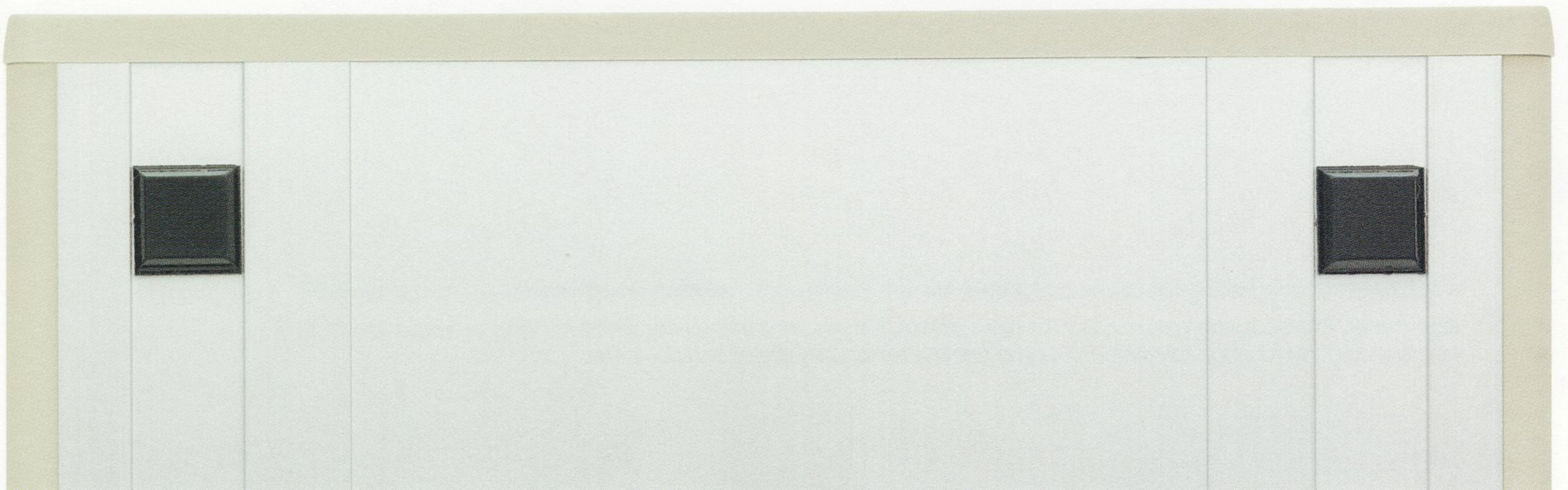

## Printed Circuit Board Mounting Options

Each C Style MicroPak Enclosure has at least one set of tracks for mounting printed circuit boards. These tracks provide an efficient and secure way to hold your board during assembly and testing and in the completed instrument.

If you have the flexibility to design to MicroPak standards, you will achieve significant cost effectiveness both in terms of enclosure cost and assembly cost. The recommended board widths are 2.51 in (63.8 mm), 3.89 in (98.8 mm), 3.94 in (100 mm Eurocard standard), 5.28 in (134.1 mm) and 7.00 in (177.8 mm). The recommended length is the same length as the cover and base.

Shorter boards may be secured by fastening to a single standoff located near one end of the board (being sure that no components are located in such a way as to impede the board from being slid into place). The same technique can be used to electrically ground a board to the base.

Narrower boards can be mounted either in one track with captive standoffs supporting the opposite side or entirely on standoffs. On Q, T and W enclosures, self-clinching standoffs 0.250 in (6.35 mm) long will support the board at the same height as the standard track.

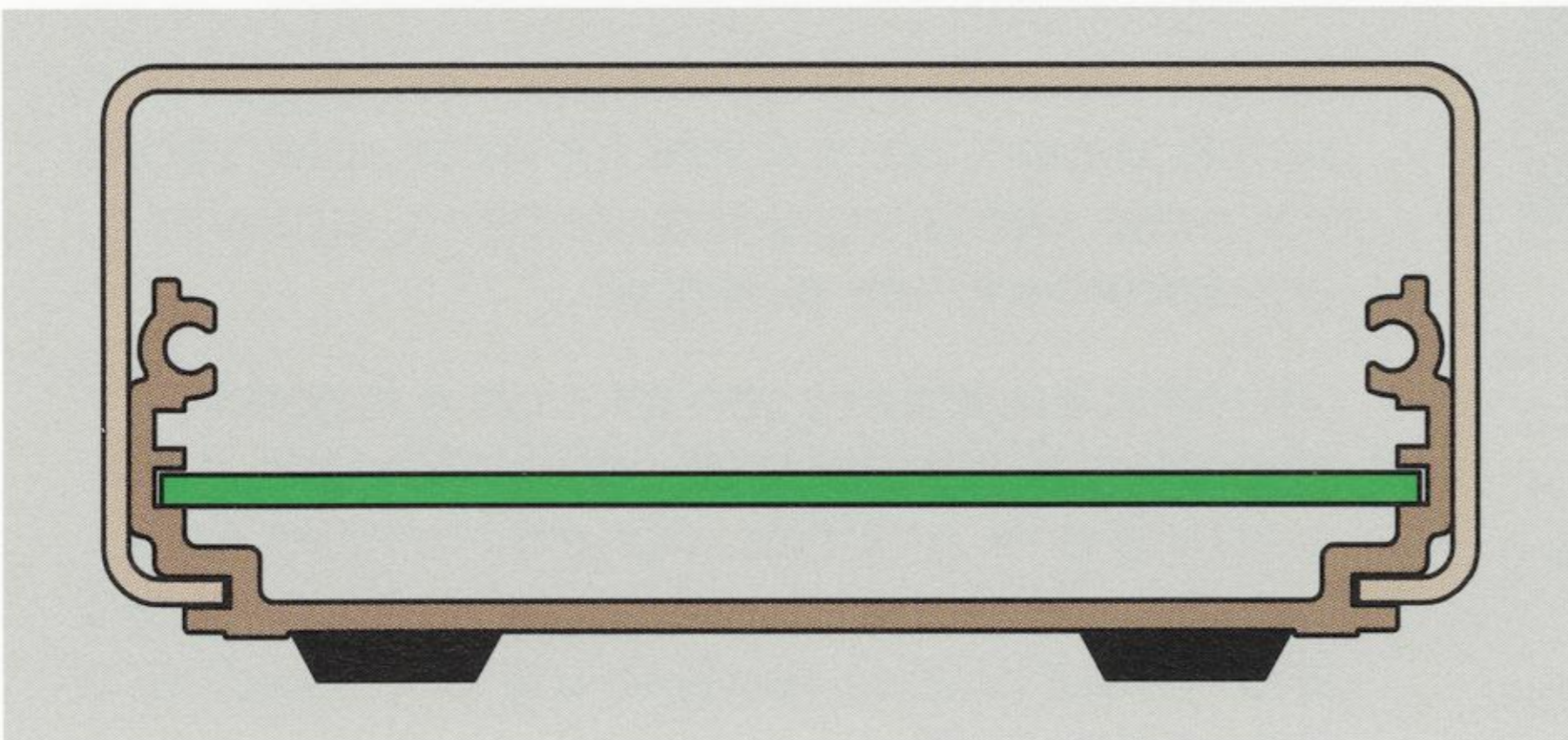

Printed circuit board mounted in standard MicroPak tracks (N2 shown actual size).

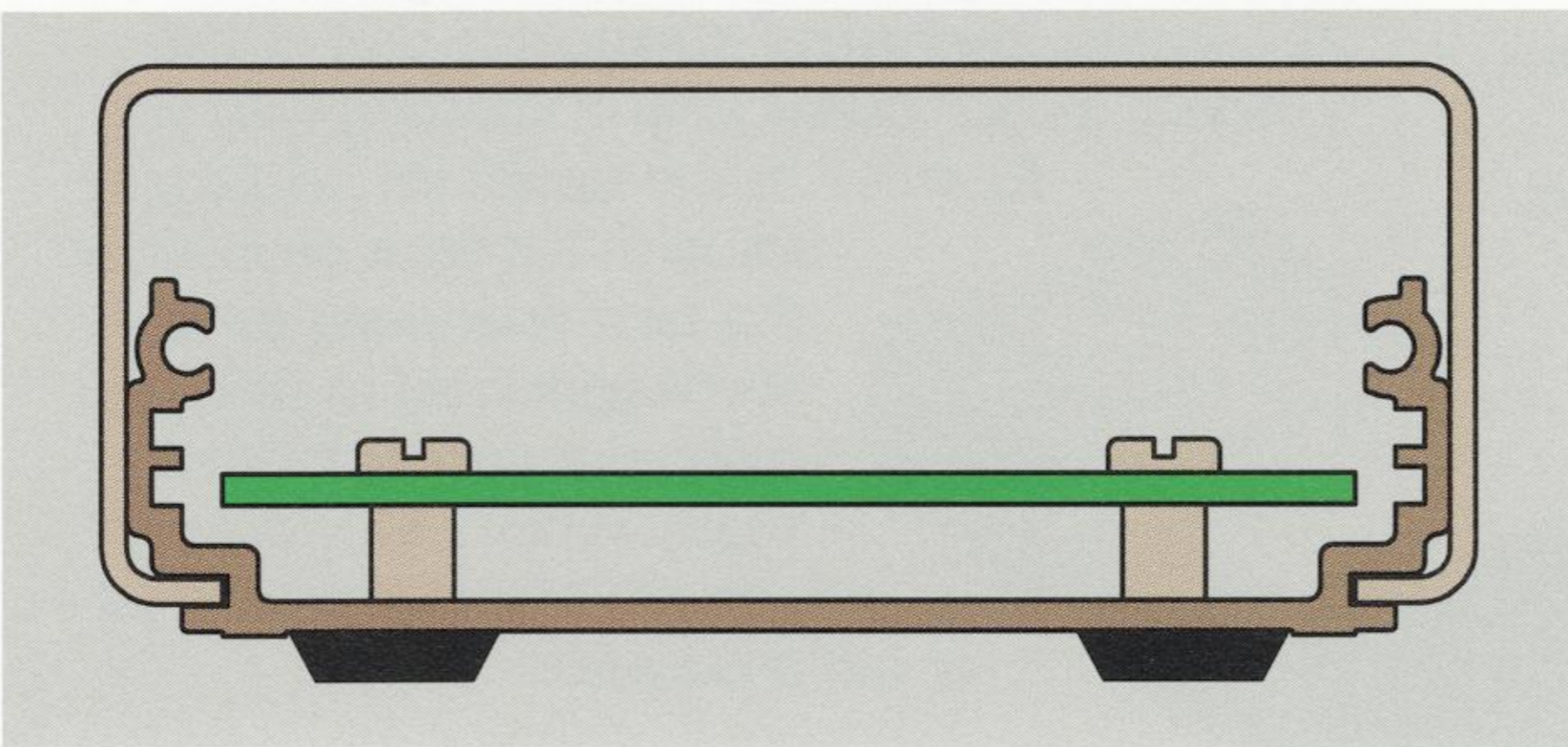

Printed circuit board mounted on self-clinching standoffs.

## Enhanced Shielding Considerations

The C Style MicroPak's design offers inherently good shielding characteristics – sufficient for most applications. For more demanding situations, three enhanced shielding options are available. All entail creating conductive interior surfaces.

**1. Clear iridite finish for end panels:** Among the standard panel choices, conductive clear iridite is the preferred finish for applications requiring enhanced shielding. Since it is a soft finish, it may not be as suitable for the cosmetic exterior surfaces. Overlays are recommended in these instances.

**2. Nickel acrylic (conductive) bezels:** This option provides bezels that have been painted (all surfaces or selected surfaces only) with conductive Nickel Acrylic. NIAC has a characteristic gray color (shown to the right in actual size on a T1 security bezel) that is well complemented by the platinum and medium gray colors.

**3. Vinyl-clad aluminum cover:** This option substitutes vinyl-clad aluminum (with a conductive iridited interior surface) for the standard vinyl-clad steel (with a nonconductive painted interior surface). Both materials have the same external appearance.

We recommend that customers who are submitting their products for testing go with an arsenal of options so that they may determine which combinations are minimally required to obtain certification. When available, we will be happy to provide complimentary samples for such purposes.



T1 security bezel with NIAC finish (shown actual size).

## Rack Mounting Options (see pages 18-19)

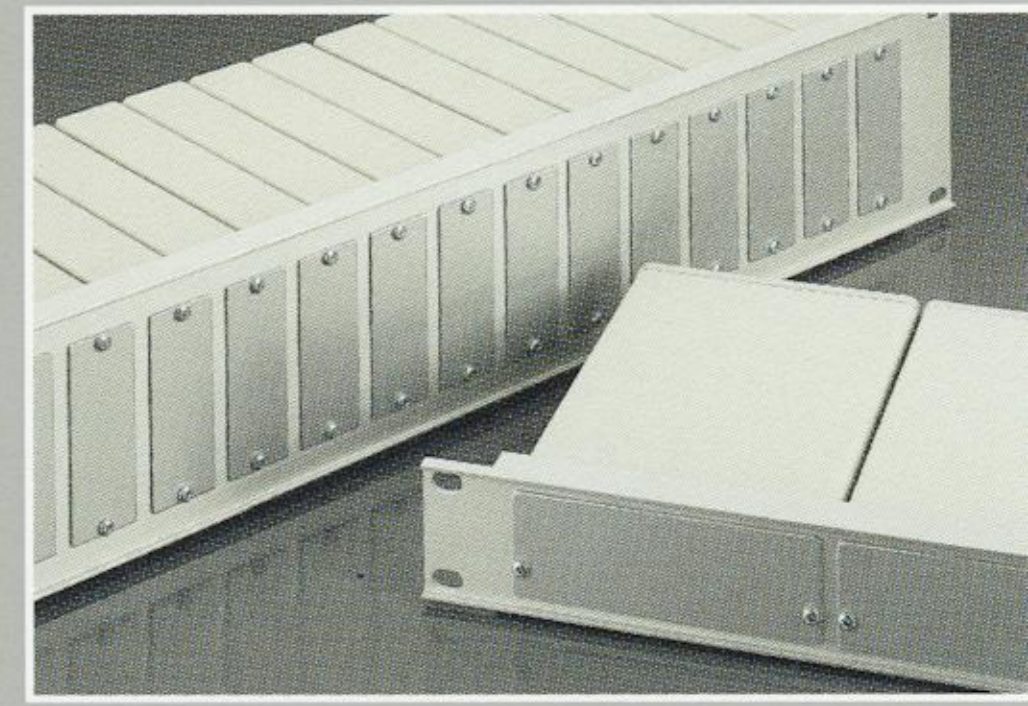

## Customization (see pages 20-21)

Find out what you can do to have us make a MicroPak distinctly yours.



## C Style Technical Data Sheet (inserted under back flap)

Find specifications, engineering drawings and other technical details.

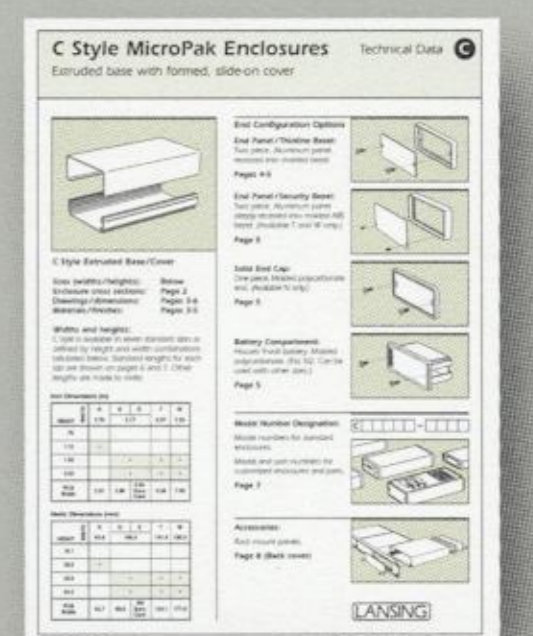

## Price List (inserted under back flap)

Find MicroPak prices.



## Order Form/Sample Offer

Place an order or purchase a sample MicroPak at a special introductory no-risk offer price.

## Technical Support (see page 22)

Learn how our experienced staff can answer your technical questions.

# D Style MicroPak Enclosures

Our simplest design  
using a one-piece, seamless extruded tube

The D Style MicroPak, with its seamless tubular construction, is the simplest of the three MicroPak

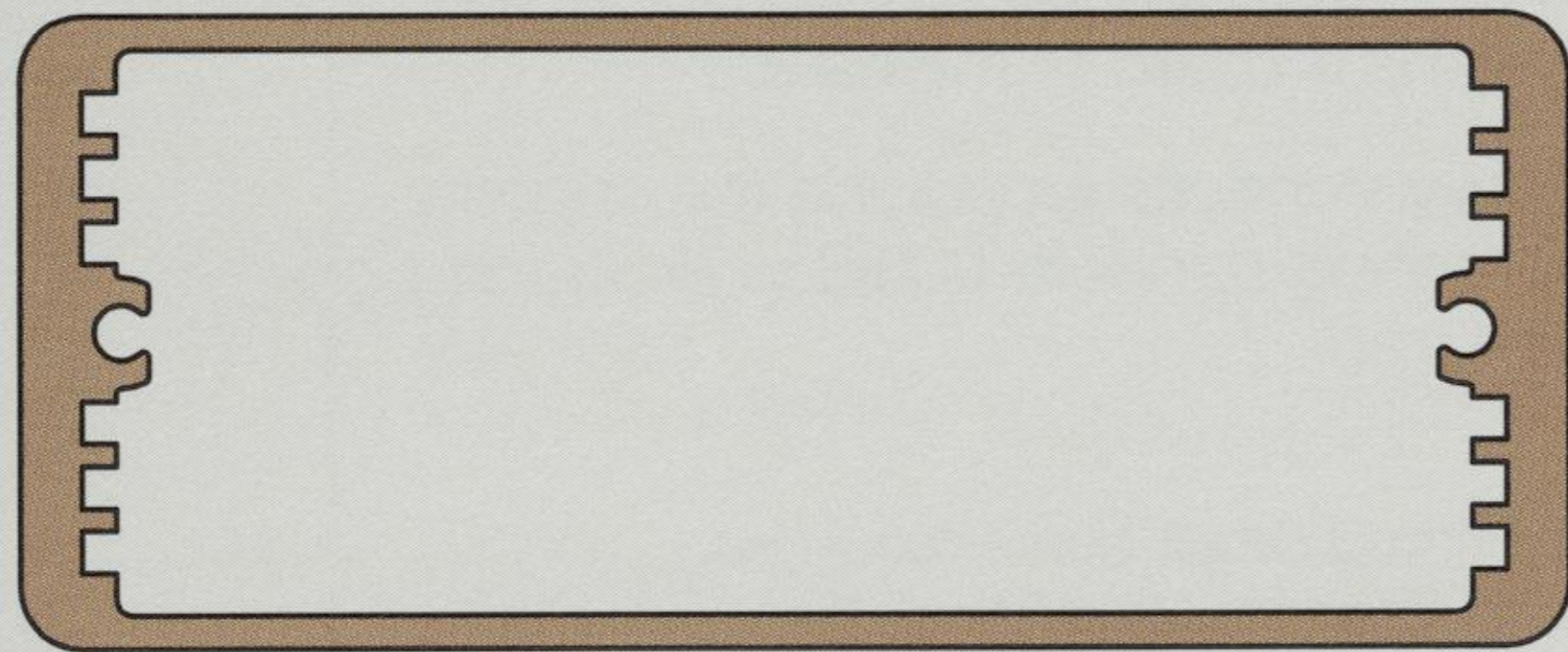

*D Style MicroPak Enclosures, shown here in typical cross-section, are characterized by a rugged one-piece seamless extruded tube. The tube contains multiple tracks for printed circuit boards. Access to the interior is through the ends.*

## Remember the MicroPak Advantages...

- Proven designs save you both development and production time.
- Reasonable pricing at any quantity saves you money.
- Flexible design readily adapts to your specific requirements.
- Quality construction and attractive appearance add value to your product.
- Simple, unobtrusive design allows your product to take on its own unique personality.
- Extensive range of sizes accommodates your growing product line.
- We get it to you fast.

For the full story, please read the inside front cover.

designs. It is ideal for small desk top and/or hand-held instruments requiring limited front and rear panel space. When used in combination with a **MicroPak Rack Mount Panel**, it is a good choice for rack mounted modular systems that may require that each unit be isolated from the others.

Select from a variety of **end configurations**. D Style offers the widest range of choices: a two-piece end panel/bezel combination, a solid molded end cap, an extended metal panel and a battery compartment. Non-skid feet may be added for desktop applications.

D Style also offers the widest range of finishes. For applications requiring a high level of cosmetics and durability, they are available in MicroPak's contemporary palette of **colors** in both warm and cool color families. For applications where an economical "industrial" finish is appropriate, D Style is available with an anodize or iridite finish.



**Interior tracks built into the extrusion provide a convenient way to mount one or more PCBs in the finished product.**

The D Style **family** has 18 standard sizes (three heights, three widths and a variety of standard lengths) available from stock. We can make almost any length to order.

Each enclosure has multiple tracks for **mounting printed circuit boards**. These tracks provide an efficient and secure way to hold your board during assembly, testing and in the completed product.

D Style **shielding** characteristics, resulting from its simple design, are suitable for most applications. For more demanding requirements, optional enhancements are available.

MicroPak Enclosures can take on a function and personality that is all yours. Whether it be machining or graphics, our experienced staff can provide the **customizing** details you need and deliver quality, ready-to-use enclosures at a reasonable cost.

At Lansing, **technical support** is part of the product. It's our philosophy of working with you to arrive at the optimum packaging solution for your product at the best final price to you. We'll work hard to help you turn your concept into a reality whether for one enclosure, an initial prototype or full production.

## D Style Widths and Heights

The entire MicroPak family (consisting of C, D and E Styles) is available in ten standard sizes defined by the height and width combinations displayed on the right.

The D Style is available in the six sizes indicated. Within each size there are one or more standard lengths (front to back) available from stock. These standard lengths are tabulated at the bottom of each column to the right. Lengths other than these are made to order.

Note that enclosure length is defined as length of the extruded tube. Overall length depends on the end configurations chosen. Refer to the D Style Technical Data Sheet.

## D Style Family

N-Width	Q-Width	T-Width	W-Width	
				.75 in (19.1 mm)
				1.12 in (28.5 mm)
				1.52 in (38.6 mm)
				2.52 in (64.0 mm)
2.75 in (69.8 mm)	4.17 in (106.0 mm)	5.53 in (140.4 mm)	7.29 in (185.0 mm)	
3.00 (76.2) 4.00 (101.6) 5.00 (127.0) 6.00 (152.4)	5.00 (127.0) 6.00 (152.4) 6.30 (160.0)*	6.00 (152.4) 7.00 (177.8)		Standard (stocked) lengths – inch (metric)
*Accepts 100 mm x 160 mm Eurocards.				Other lengths are made to order.

**Precision Interchangeable Parts** have close mechanical tolerances.

**Fast, Efficient Assembly** – As few as three parts plus four screws.

**Extruded Aluminum Tube** provides a rugged housing.

**Clean Styling** – Small sizes are comfortable for hand-held applications.

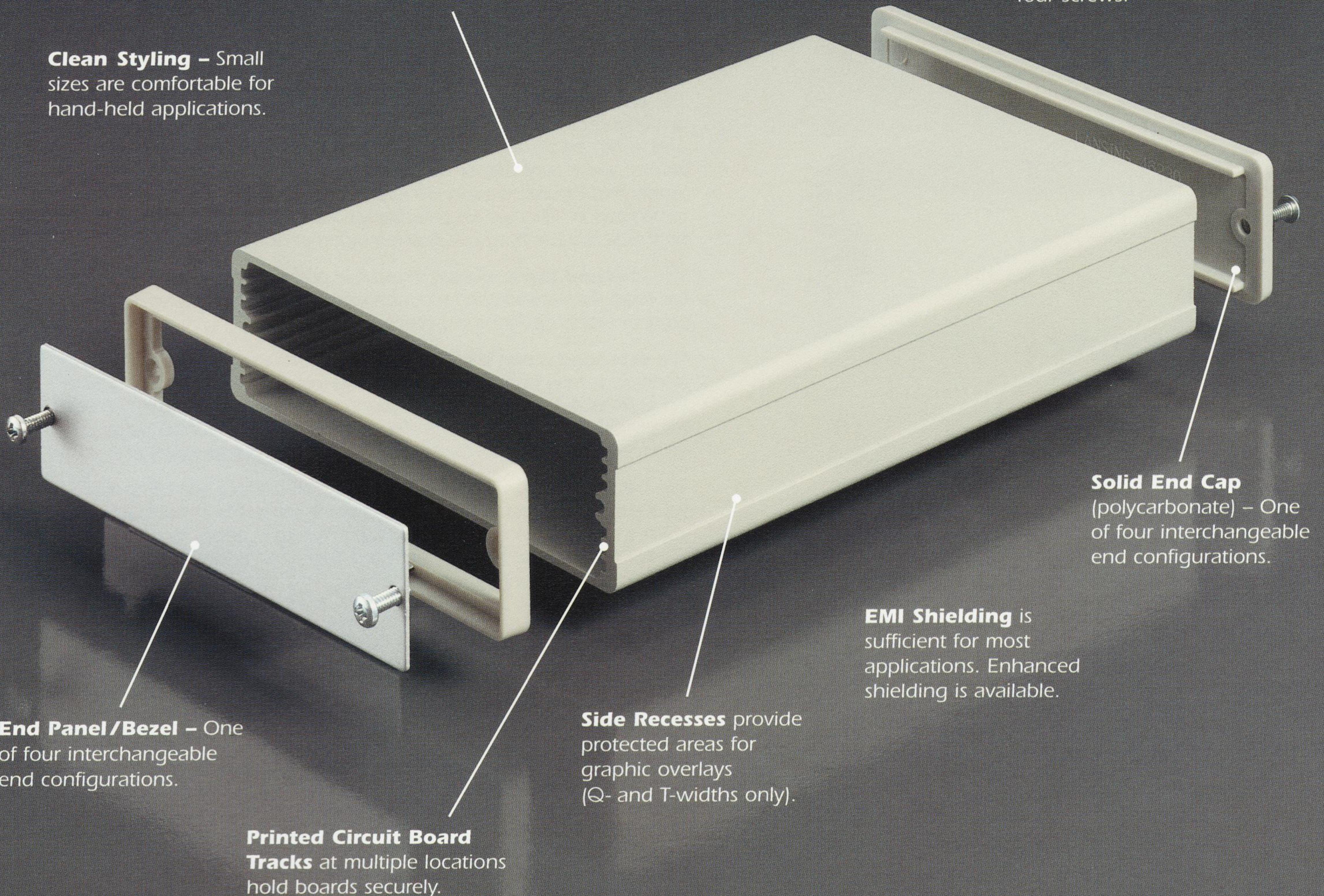

**MicroPak Enclosures accommodate your growing product line** by providing a comprehensive family of enclosures with complementary appearance and construction across all styles (C, D and E). The D Style, characterized by a one-piece, seamless extruded tube, is available in both standard and nonstandard sizes. There are 18 standard sizes in stock – all available in Lansing's full palette of colors. Nonstandard sizes are made to order.

Your first MicroPak will demonstrate how accommodating its design can be, how simply and quickly one can go from prototype to production and how much it can enhance the presentation of your product. And as you add new products to your line, the look you've already established can be maintained (both within the D Style and across styles), minimizing the need for additional development costs and building on the equity of your earlier product.





**N-, Q- or T-width extruded tube.**  
(N2 shown actual size)



**End Panel/Thinline Bezel.** Available with pan head or flat head screws. Easy to machine. Ideally suited for silkscreening or overlays.



**Solid End Cap.** Available with flat head screws. Can be machined. Designed to accept an overlay.



**Battery Compartment.** 9-volt battery housing with convenient sliding access cover. Fits N2 enclosures. Can also be used in any larger MicroPak Enclosure.

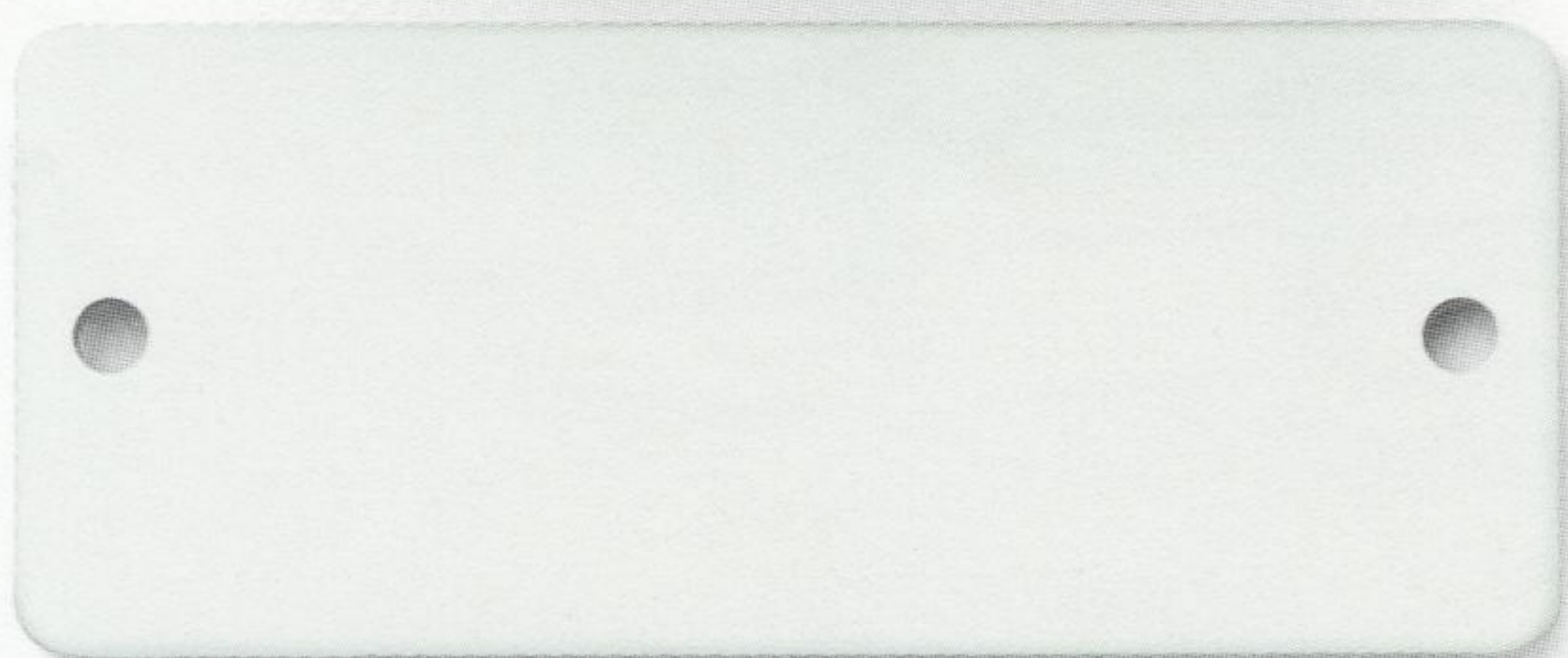

**Extended Metal Panel.** Mounts flush with extrusion profile. Available with pan head screws. Easy to machine and silkscreen.

## D Style End Configurations

Each end of a D Style MicroPak Enclosure can be fitted with an **end panel/bezel** combination, a **solid end cap** (molded), an **extended metal panel** or a **battery compartment**.

The **end panel/bezel** combination is the most versatile option and is available on all sizes. The end panel is a flat metal plate that recesses into and is framed by the molded plastic bezel. It comes in a variety of finishes and is available for use with pan head or flat head screws. Holes, inserts and/or silkscreening are easily added, making it well suited for customization. Overlays are particularly suitable since all edges are protected by the bezel. Standard bezels are molded in durable polycarbonate.

The solid **end cap** is molded in durable polycarbonate. It is used with flat head screws and can be customized by milling or drilling. It has a shallow recess designed to accept an overlay.

The **extended metal panel** mounts flush with the extrusion profile. The standard version (shown bottom left) mounts with two pan head screws. An optional **4-hole panel** with mounting holes in each corner is available for the Q1 and T1 enclosures. These parts are easy to machine and silkscreen. They are ideal for applications requiring an all metal enclosure.

The **battery compartment**, also molded in durable polycarbonate, houses a 9-volt battery. Access to the compartment is through a sliding cover that snaps conveniently and securely into position. It specifically fits the N2 size but may be used with any larger MicroPak Enclosure as an insert in an end panel, base or cover.

### Optional Non-Skid Feet

(shown actual size) – Non-skid feet that prevent the unit from sliding on flat surfaces are optional on D Style Enclosures. When this option is selected, the feet are applied to the extruded tube prior to shipping.

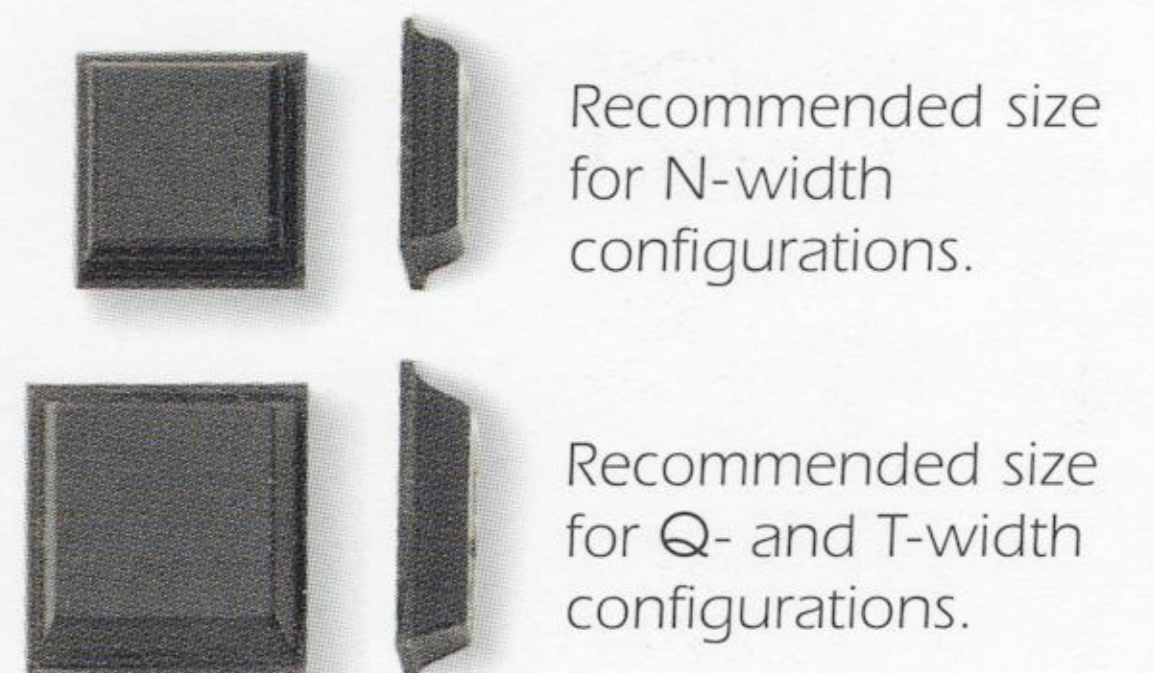

### Phillips Pan Head or Phillips Flat Head Screws

(shown actual size) – Available in silver or black. Note: End panel screw holes are automatically countersunk for flat head screws.



### Extended Metal Panel with 4-Hole Option.

Available for DQ1 (shown actual size) and DT1 models. Mounts flush with extrusion profile. Available with pan head screws. Easy to machine and silkscreen.

## D Style Color Choices

(shown 50% actual size)

MicroPak Enclosures are available in a contemporary palette of colors comprised of two color families – a warm family that is IBM compatible and a cool family, including some that are Apple compatible. To create the perfect color scheme for your finished product, choose from the options shown on the right.

Mix or match bezel/end cap and tube colors bearing in mind that your choices of panel finish, graphics, screw type and screw color also contribute to the overall final appearance. The charts should be regarded as a relative rather than an absolute representation of color. Actual color chips are available on request.

**Custom colors** are available. Refer to the Customization section on pages 20-21.



Depending on application, **optional finishes** can be considered for the extruded tube. Iridite can be used when surface conductivity is required. Anodize can be used when durability is needed at a lower price. Neither is suitable when cosmetics are a primary concern.

## Printed Circuit Board Mounting

Each D Style MicroPak Enclosure has multiple sets of tracks for mounting printed circuit boards. These tracks provide an efficient and secure way to hold your board during assembly and testing and in the completed instrument. The recommended board widths are 2.51 in (63.8 mm), 3.94 in (100 mm Eurocard standard) and 5.28 in (134.1 mm). The recommended length is the same length as the tube.

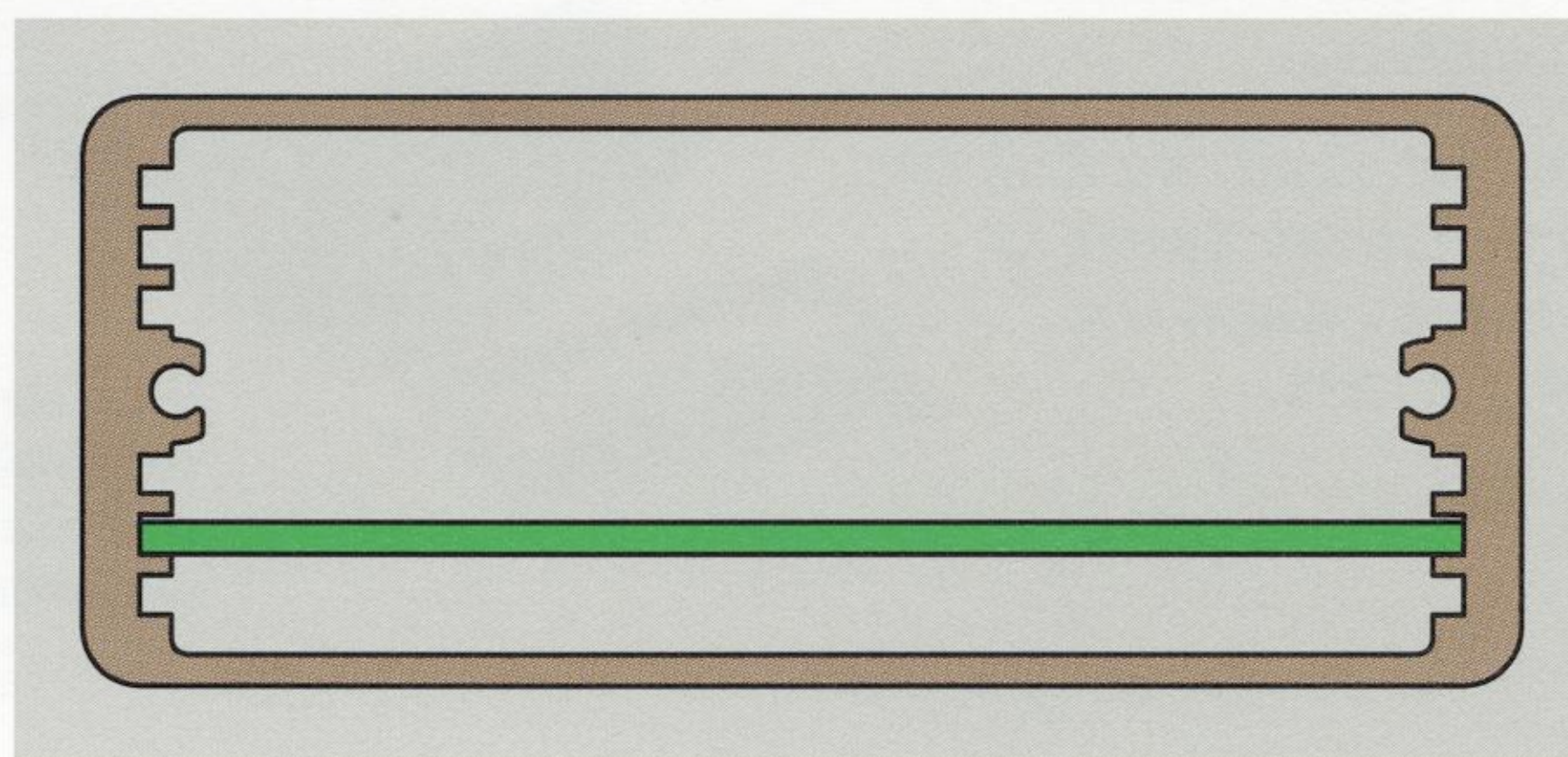

Printed circuit board mounted in standard MicroPak tracks (N2 shown actual size).

## Enhanced Shielding Considerations

The D Style MicroPak's design offers inherently good shielding characteristics. For more demanding applications, three enhancements should be considered:

1. If cosmetics are not important, a **clear iridite finish** (conductive) should be selected for the tube and end panels.
2. If cosmetics are important, the ends and interior of the tube can be **masked and iridited** while the exposed surfaces are powdercoat painted.
3. **Nickel acrylic (conductive) paint** can be applied to all or selected surfaces of any molded bezel or end cap.

When available, we will be happy to provide complimentary samples for testing and evaluation.



N1 end cap with NIAC finish (shown actual size).

## Rack Mounting Options

(see pages 18-19)

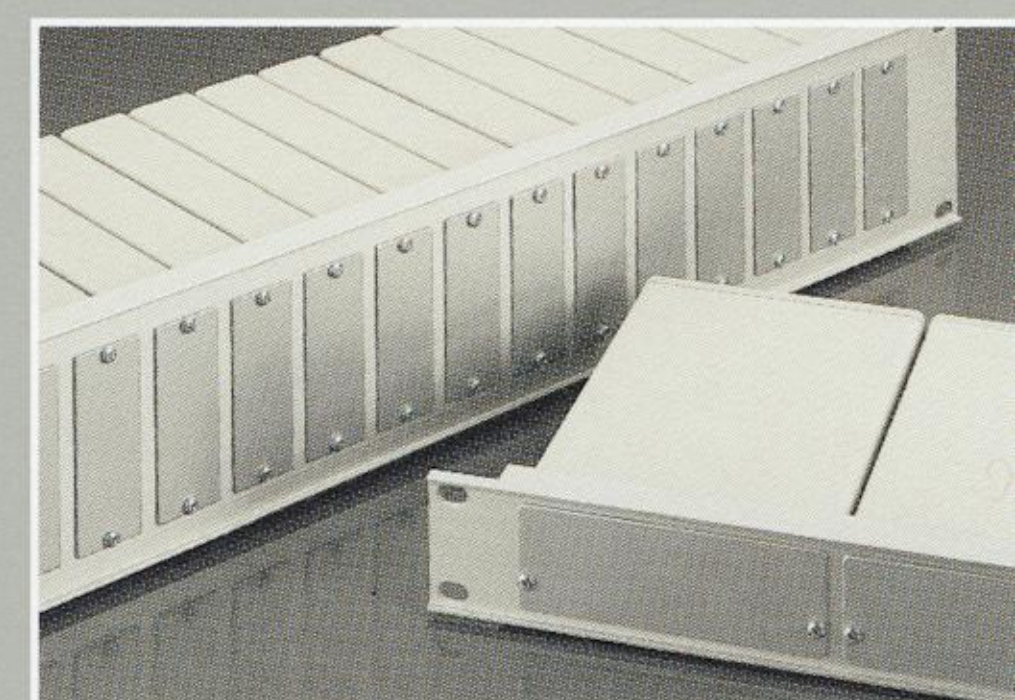

## Customization

(see pages 20-21)

Find out what you can do to have us make a MicroPak distinctly yours.



## D Style Technical Data Sheet

(inserted under back flap)

Find specifications, engineering drawings and other technical details.

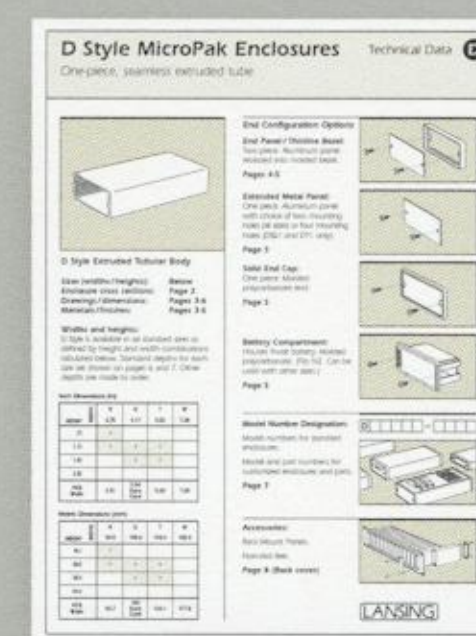

## Price List

(inserted under back flap)

Find MicroPak prices.

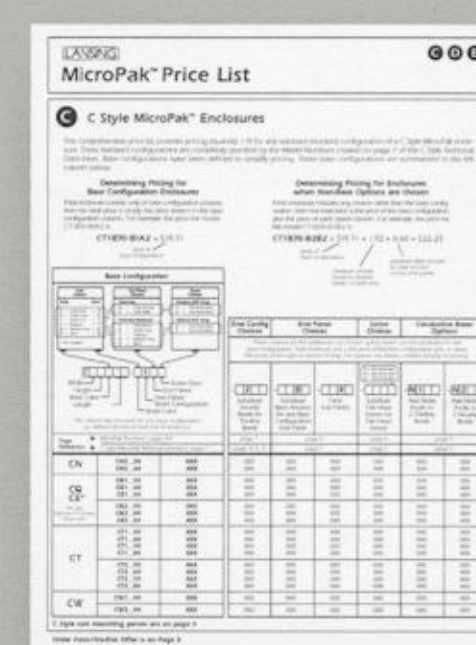

## Order Form/Sample Offer

Place an order or purchase a sample MicroPak at a special introductory no-risk offer price.

## Technical Support

(see page 22)

Learn how our experienced staff can answer your technical questions.

# E Style MicroPak Enclosures

Optimized design for maximum control-panel area with extruded base and slide-in flat panel

The E Style MicroPak is optimized for small desk top and/or hand-held instruments requiring a relatively large control panel area.

*E Style MicroPak Enclosures, shown here in typical cross-section with optional non-skid feet, are characterized by a tubular body consisting of a rugged extruded base with a slide-in flat panel. The base contains multiple tracks for printed circuit boards while the removable panel provides ample space for controls.*

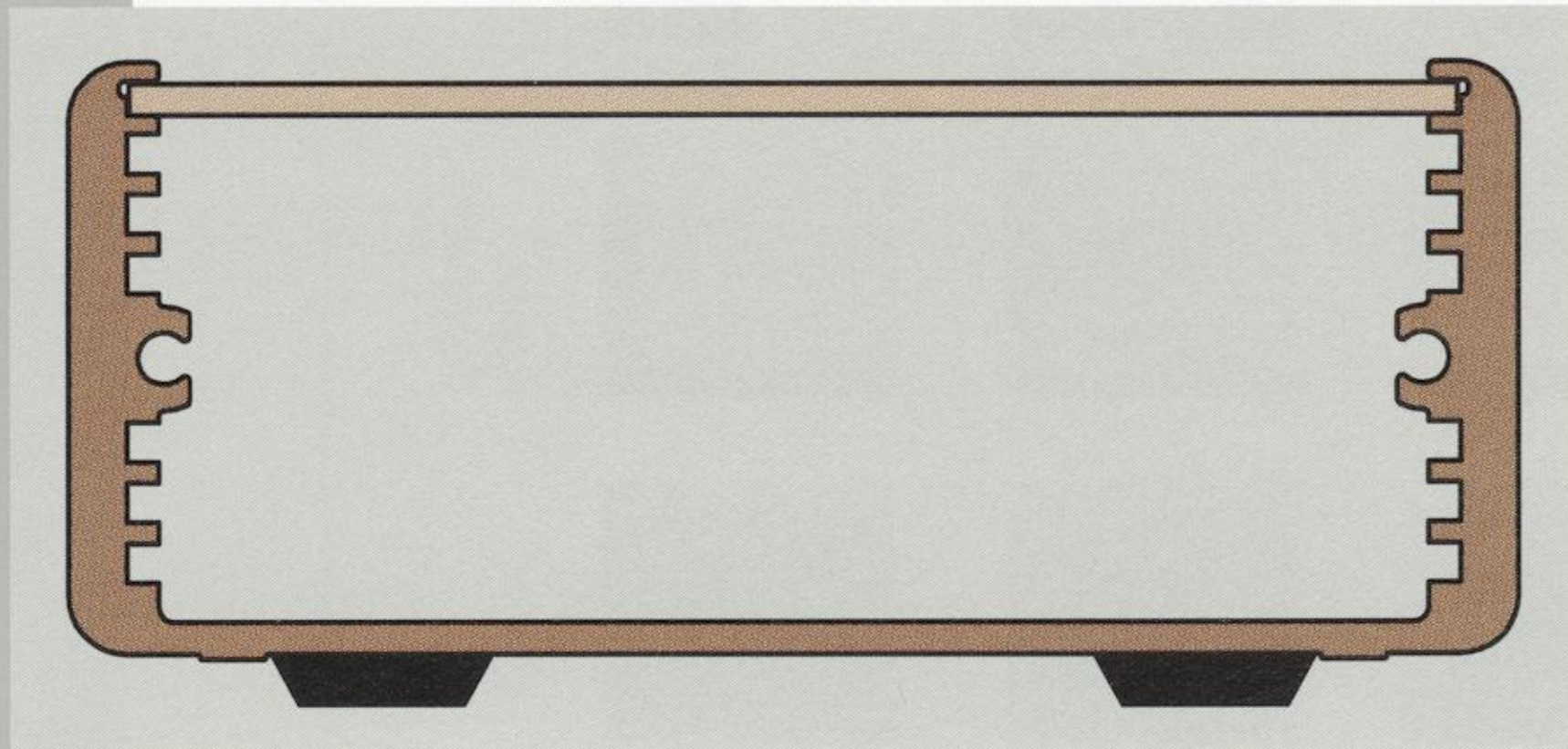

Its rugged body construction incorporates an extruded base and flat slide-in top panel. Select from various **top panel choices** to obtain the appearance you desire: overlays over an aluminum substrate or silkscreening on an anodized or painted panel.

Select from a variety of **end configurations**. These ends can be used as additional panel/control areas or simply to seal the ends of the tube. E Style offers three choices: a two-piece panel/bezel combination, a solid end cap and a battery compartment. **Bottom details** include optional non-skid feet for desktop applications and a recessed area for product labeling.

MicroPak Enclosures are available in a contemporary palette of **colors** in both warm and cool color families.

The E Style **family** has 14 standard sizes (three heights, three widths and a variety of standard lengths) available from stock. We can make almost any length to order.

Each enclosure has multiple tracks for **mounting printed circuit boards**. These tracks provide an efficient and secure way to hold your board during assembly, testing and in the completed product. Alternatively, boards may be mounted on standoffs to either the extruded base or the slide-in cover.

E Style can be mounted in a standard 19-inch rack using a **MicroPak Rack Mount Panel**.

MicroPak Enclosures can take on a function and personality that is all yours. Whether it be machining or graphics, our experienced staff can provide the **customizing** details you need and deliver quality, ready-to-use enclosures at a reasonable cost.

At Lansing, **technical support** is part of the product. It's our philosophy of working with you to arrive at the optimum packaging solution for your product at the best final price to you. We'll work hard to help you turn your concept into a reality whether for one enclosure, an initial prototype or full production.



**Interior tracks on the extruded base side rails provide a convenient way to mount one or more PCBs during assembly and in the finished product.**

### Remember the MicroPak Advantages...

- Proven designs save you both development and production time.
- Reasonable pricing at any quantity saves you money.
- Flexible design readily adapts to your specific requirements.
- Quality construction and attractive appearance add value to your product.
- Simple, unobtrusive design allows your product to take on its own unique personality
- Extensive range of sizes accommodates your growing product line.
- We get it to you fast.

For the full story, please read the inside front cover.

### E Style Widths and Heights

The entire MicroPak family (consisting of C, D and E Styles) is available in ten standard sizes defined by the height and width combinations displayed on the right.

The E Style is available in the six sizes indicated. Within each size there are one or more standard lengths (front to back) available from stock. These standard lengths are tabulated at the bottom of each column to the right. Lengths other than these are made to order.

Note that enclosure length is defined as length of the base and slide-in panel. Overall length depends on the end configurations chosen. Refer to the E Style Technical Data Sheet.

## E Style Family

N-Width	Q-Width	T-Width	W-Width	
EN1				.75 in (19.1 mm)
EN2	EQ0	ET0		1.12 in (28.5 mm)
	EQ1	ET1		1.52 in (38.6 mm)
				2.52 in (64.0 mm)
2.75 in (69.8 mm)	4.17 in (106.0 mm)	5.53 in (140.4 mm)	7.29 in (185.0 mm)	
5.00 (127.0) 6.00 (152.4)	5.00 (127.0) 6.00 (152.4) 6.30 (160.0)*	6.00 (152.4) 7.00 (177.8)		Standard (stocked) lengths - inch (metric)
*Accepts 100 mm x 160 mm Eurocards.				Other lengths are made to order.

**Precision Interchangeable Parts** have close mechanical tolerances.

**Fast, Efficient Assembly** – As few as four parts plus four screws.

**Clean Styling** – Small sizes are comfortable for hand-held applications.

**Top Panel** provides a spacious, recessed and bezeled control panel.

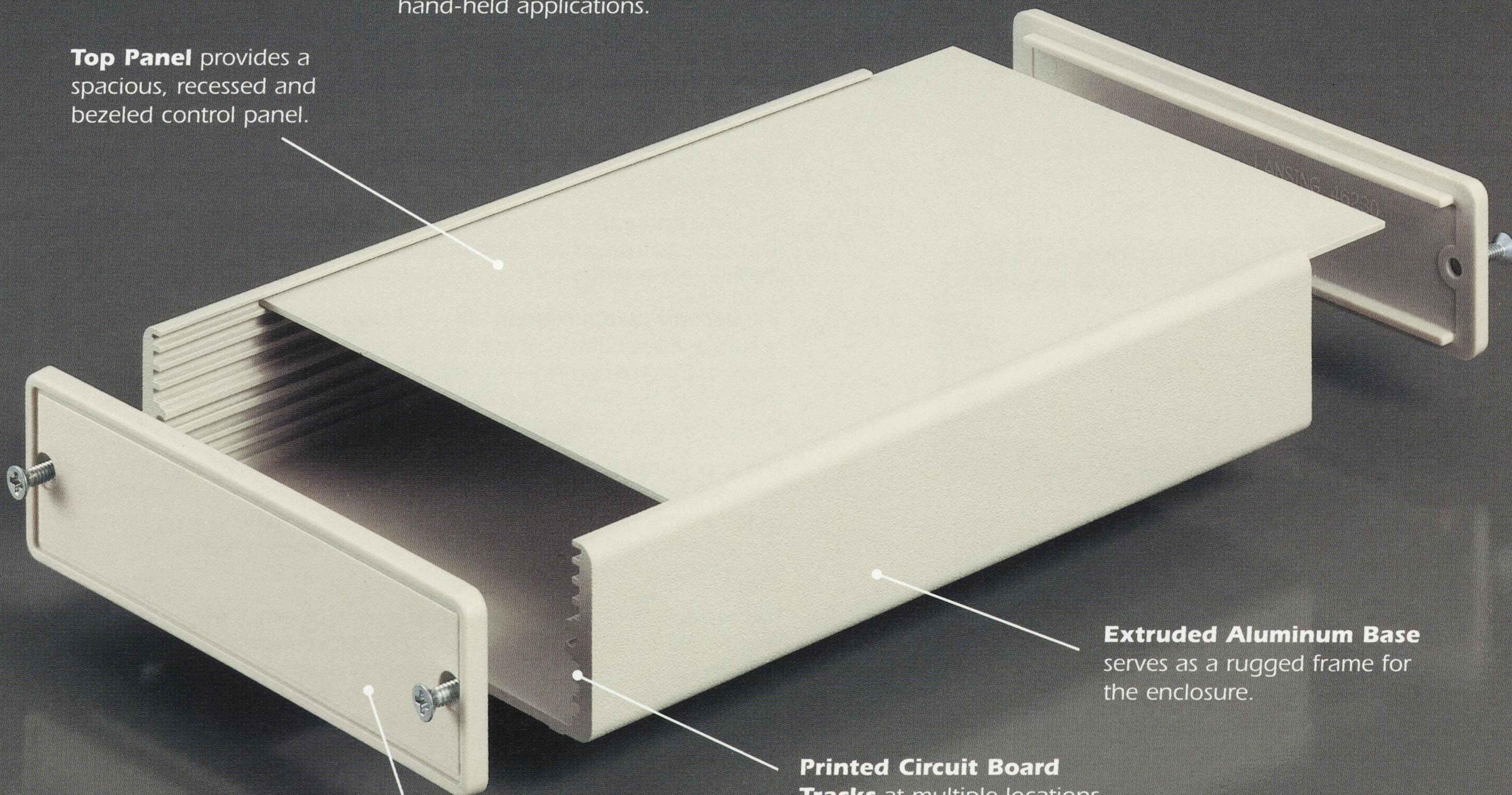

**Extruded Aluminum Base** serves as a rugged frame for the enclosure.

**Printed Circuit Board Tracks** at multiple locations hold boards securely.

**Solid End Cap** (polycarbonate) – One of three interchangeable end configurations.

**MicroPak Enclosures accommodate your growing product line**

by providing a comprehensive family of enclosures with complementary appearance and construction across all styles (C, D and E). The E Style, characterized by an extruded base with slide-in flat panel, is available in both standard and nonstandard sizes. There are 14 standard sizes in stock – all available in Lansing's full palette of colors. Nonstandard sizes are made to order.

Your first MicroPak will demonstrate how accommodating its design can be, how simply and quickly one can go from prototype to production and how much it can enhance the presentation of your product. And as you add new products to your line, the look you've already established can be maintained (both within the E Style and across styles), minimizing the need for additional development costs and building on the equity of your earlier product.



**E**

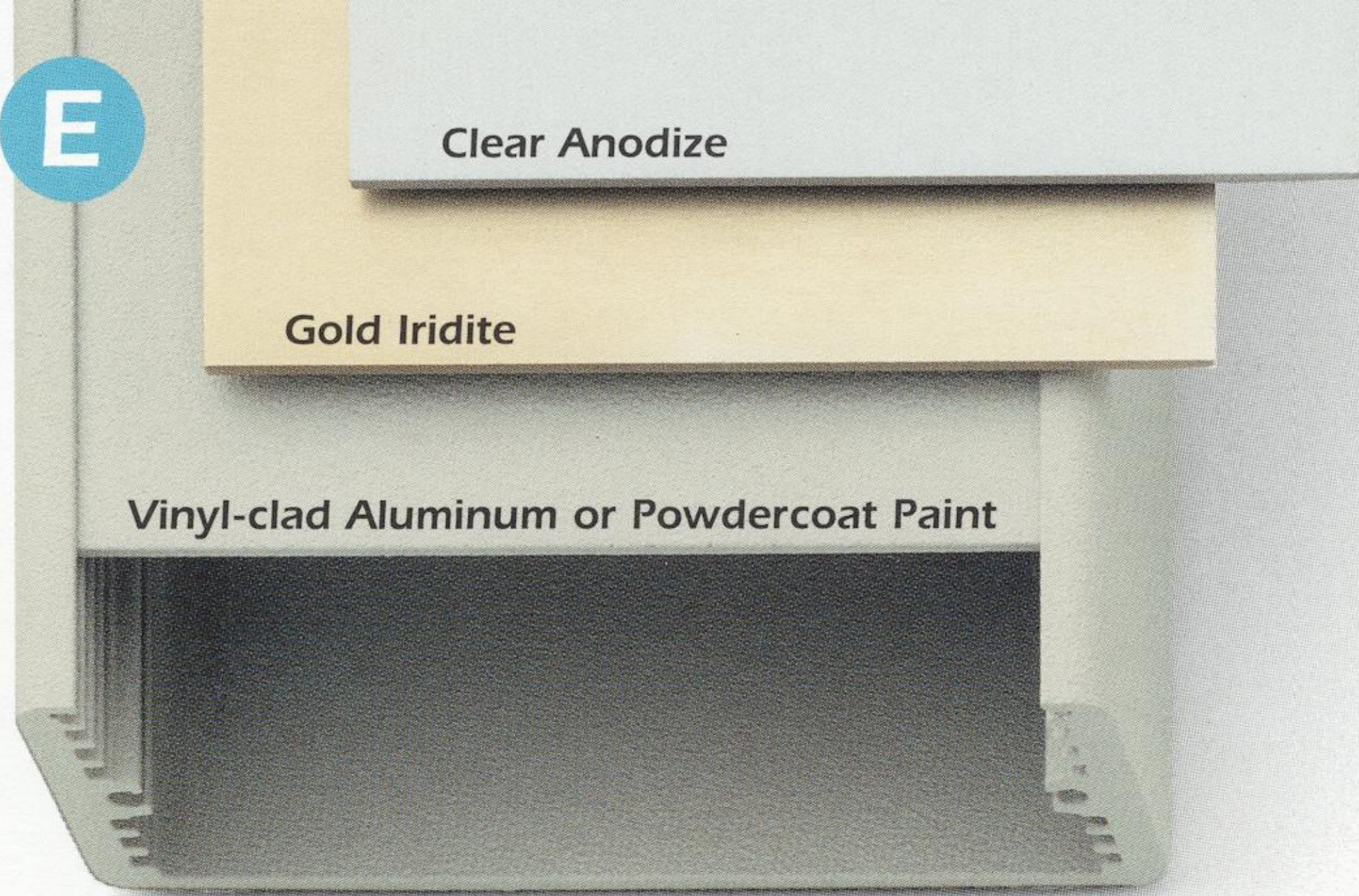

**N-, Q- or T-width extruded base with slide-in flat panel.** (N2 shown actual size)

## E Style End Configurations and Top Panel Choices

Each end of an E Style MicroPak Enclosure can be fitted with an **end panel/bezel** combination, a **solid end cap** or a **battery compartment**.

The **end panel/bezel** combination is the most versatile option and is available on all sizes. The end panel is a flat metal plate that recesses into and is framed by the molded plastic bezel. It comes in a variety of finishes and is available for use with pan head or flat head screws. Holes, inserts and/or silkscreening are easily added, making it well suited for customization. Overlays are particularly suitable since all edges are protected by the bezel. Standard bezels are molded in durable polycarbonate.

The solid **end cap** is molded in durable polycarbonate. It is used with flat head screws and can be customized by milling or drilling. It has a shallow recess designed to accept an overlay.

The **battery compartment**, also molded in durable polycarbonate, houses a 9-volt battery. Access to the compartment is through a sliding cover that snaps conveniently and securely into position. It specifically fits the N2 size but may be used with any larger MicroPak Enclosure as an insert in an end panel, base or cover.

The **top panel** is a recessed, flat metal plate that slides into the extruded base. It is available in two thicknesses and a variety of finishes. Holes, inserts or silkscreening are easily added, making it well suited to customization. Overlays are particularly suitable since all edges are protected.

The available thicknesses are 0.050 in (1.27 mm) and 0.060 in (1.52 mm). The thinner panel is appropriate for applications using overlays and for standard parts that are either vinyl-clad or powdercoat painted. The recommended thickness for overlays is 0.010 in (0.25 mm). The thicker panel is appropriate when the desired finish is either clear or black anodize.

While the intended design is for the top panel to be the “top” of the instrument, it should be noted that there are legitimate applications where inverting the design may be beneficial.

## E Style Bottom Details

**Non-skid feet** that prevent the unit from sliding on flat surfaces are optional on E Style Enclosures. When this option is selected, the feet are applied to the extruded base prior to shipping. (Optional non-skid feet shown actual size). A **recessed area** on the bottom surface is suitable for labels.

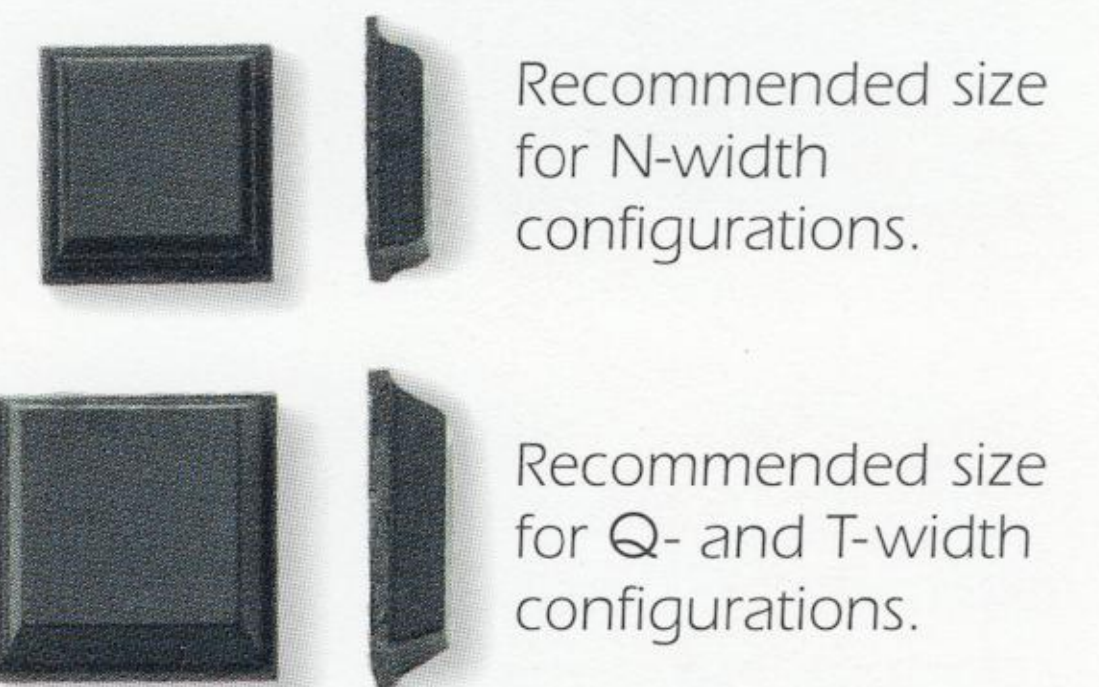

Shown actual size for Q-width.



**End Panel/Thinline Bezel.** Available with pan head or flat head screws. Easy to machine. Ideally suited for silkscreening or overlays.



**Solid End Cap.** Available with flat head screws. Can be machined. Designed to accept an overlay.



**Battery Compartment.** 9-volt battery housing with convenient sliding access cover. Fits N2 enclosures. Can also be used in any larger MicroPak Enclosure.



**Phillips Pan Head or Phillips Flat Head Screws** (shown actual size) – Available in silver or black. Note: End panel screw holes are automatically countersunk for flat head screws.

## E Style Color Choices

(shown 50% actual size)

MicroPak Enclosures are available in a contemporary palette of colors comprised of two color families – a warm family that is IBM compatible and a cool family, including some that are Apple compatible. To create the perfect color scheme for your finished product, choose from the options shown on the right.

Mix or match bezel/end panel and base/top panel colors bearing in mind that your choices of panel finishes, graphics, screw type and screw color also contribute to the overall final appearance. The charts should be regarded as a relative rather than an absolute representation of color. Actual color chips are available on request.

**Custom colors** are available. Refer to the Customization section on pages 20-21.

	Pearl White Bezel	Pebble Gray Bezel	Shale Gray Bezel	
Pearl White Cover				IBM Compatible
Pebble Gray Cover				
	Platinum Bezel	Med. Gray Bezel	Black Bezel	
Platinum Cover				Apple Compatible
Medium Gray Cover				
Black Cover				

## Rack Mounting Options (see pages 18-19)

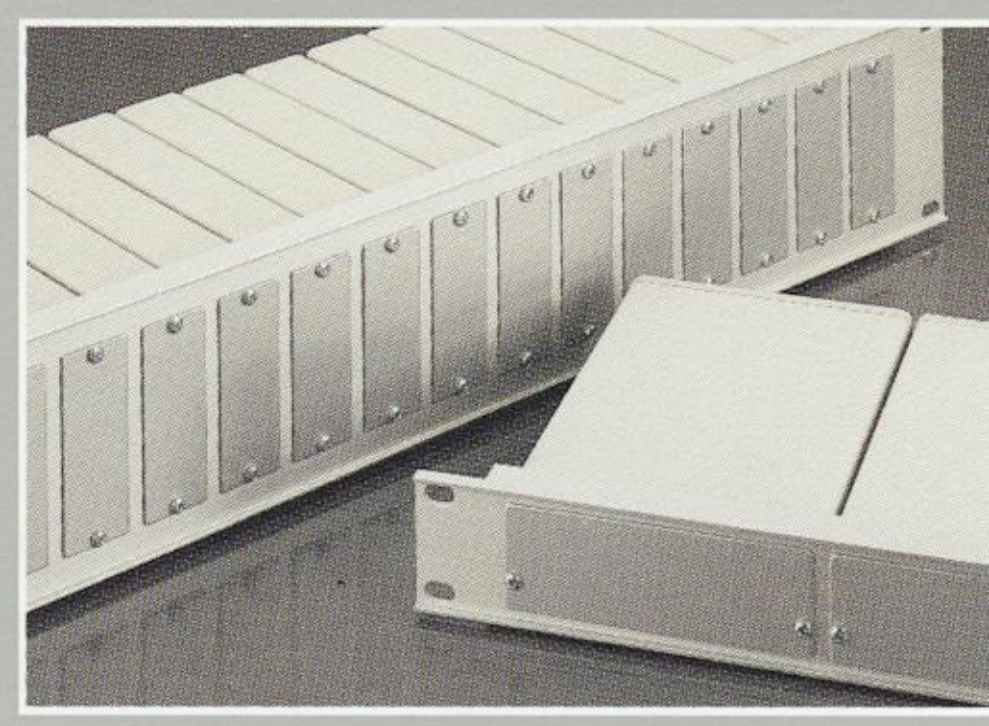

## Customization (see pages 20-21)

Find out what you can do to have us make a MicroPak distinctly yours.



## Printed Circuit Board Mounting Options

Each E Style MicroPak Enclosure has multiple sets of tracks for mounting printed circuit boards. These tracks provide an efficient and secure way to hold your board during assembly and testing and in the completed instrument.

If you have the flexibility to design to MicroPak standards, you will achieve significant cost effectiveness both in terms of enclosure cost and assembly cost. The recommended board widths are 2.51 in (63.8 mm), 3.94 in (100 mm Eurocard standard) and 5.28 in (134.1 mm). The recommended length is the same length as the cover and base.

Shorter boards may be secured by fastening to a single standoff located near one end of the board (being sure that no components are located in such a way as to impede the board from being slid into place). The same technique can be used to electrically ground a board to the base.

Narrower boards can be mounted to either the extruded base or the slide-in panel via standoffs. If board-mounted components must protrude through the panel, the PCB should be mounted to the panel.

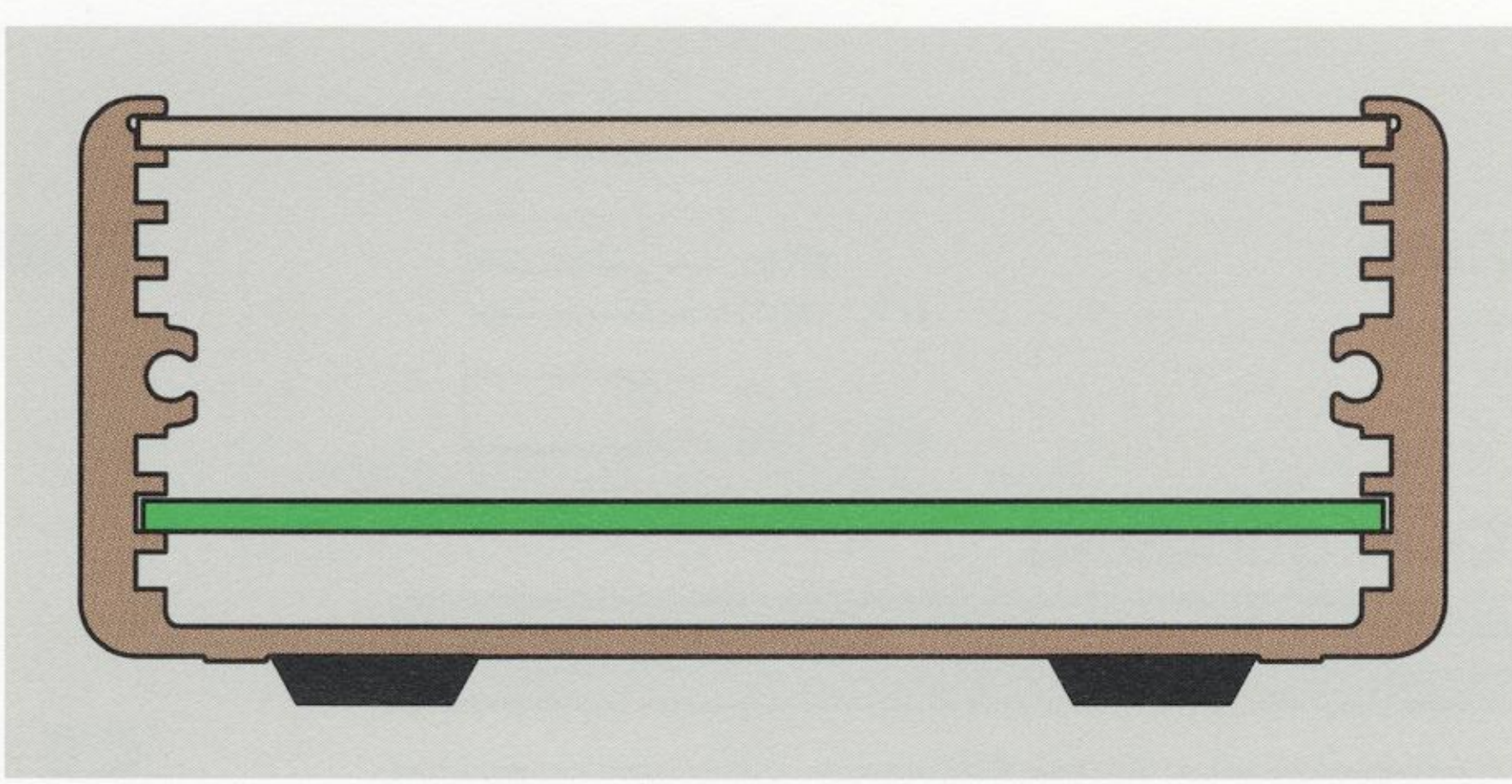

Printed circuit board mounted in standard MicroPak tracks (N2 shown actual size).

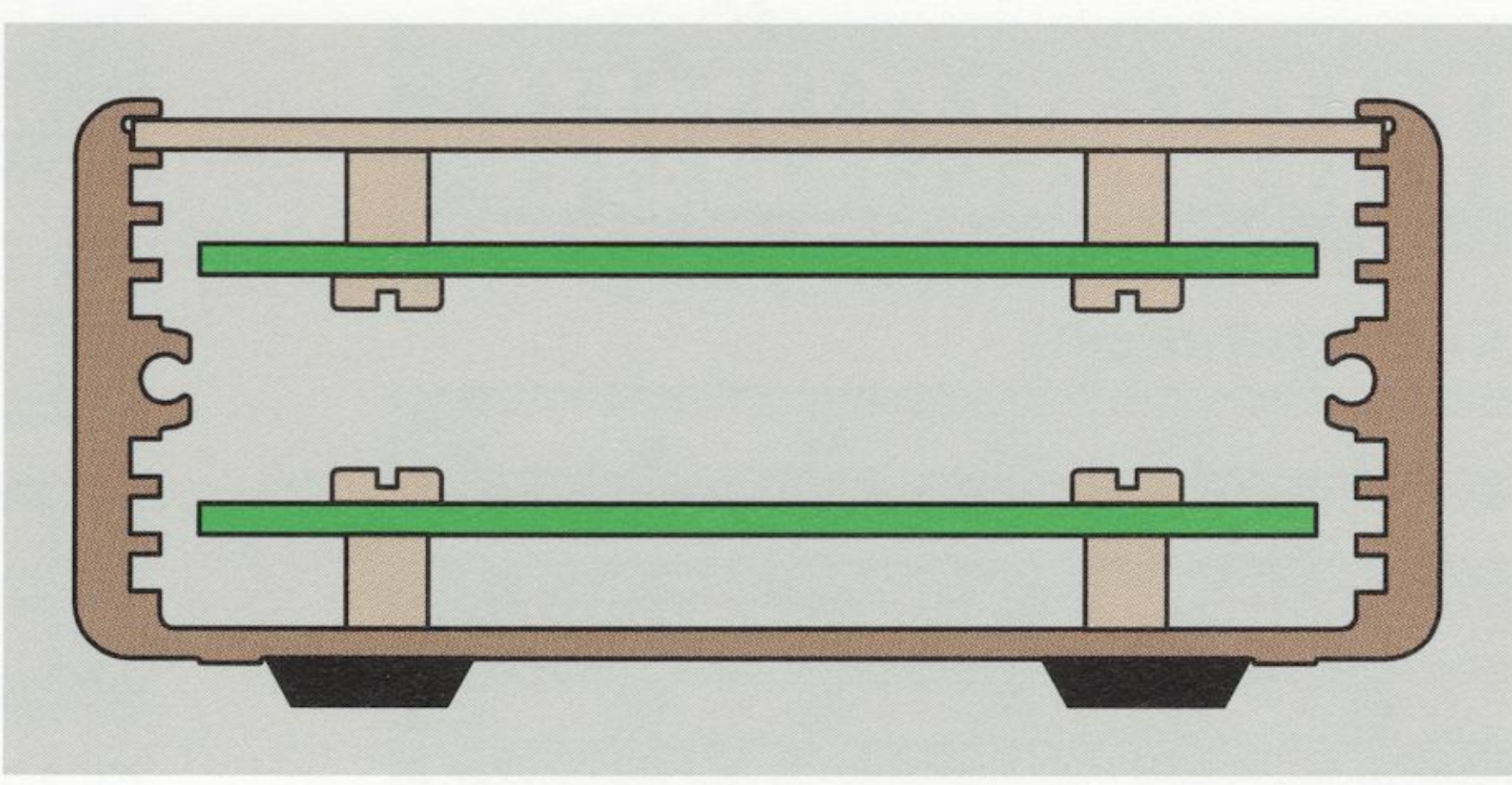

Printed circuit board mounted to the base via self-clinching standoffs. May also be mounted to the slide-in panel.

## E Style Technical Data Sheet (inserted under back flap)

Find specifications, engineering drawings and other technical details.

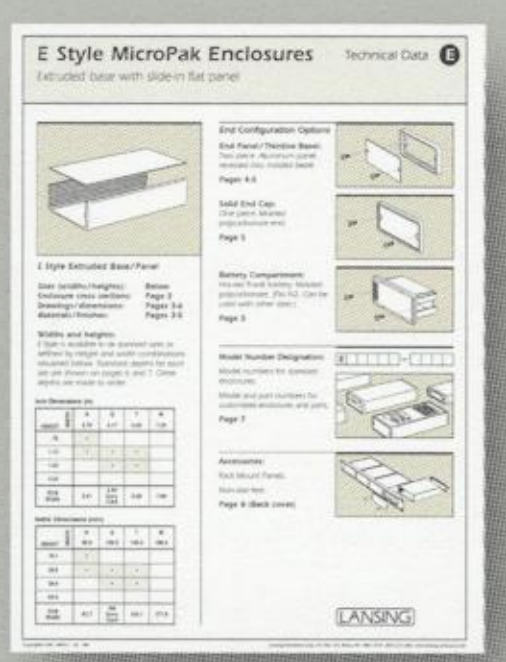

## Price List (inserted under back flap)

Find MicroPak prices.

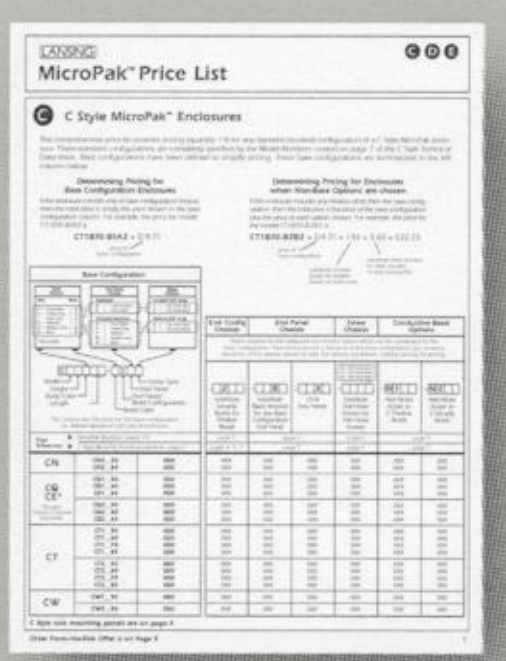

## Order Form/Sample Offer

Place an order or purchase a sample MicroPak at a special introductory no-risk offer price.

## Technical Support (see page 22)

Learn how our experienced staff can answer your technical questions.

# MicroPak Rack Mount Panels

For rack mounting MicroPak Enclosures

*MicroPak Rack Mount Panels provide a means of mounting MicroPak Enclosures in a standard 19-inch rack. Panels exist for mounting all widths in horizontal configurations. In addition, N-widths may be mounted vertically. Shown here are two of the 23 different standard panels: one is a two-rack unit panel capable of mounting up to 14 N2-sized enclosures vertically, while the other is a one-rack unit panel for mounting up to four Q1-sized enclosures horizontally.*



All MicroPak Enclosures can be mounted in a standard 19-inch rack using a MicroPak Rack Mount Panel. This option adds versatility to your products by allowing you an easy way to place them into rack environments. You are not limited to stand-alone and hand-held applications.

Lansing offers a comprehensive family of 23 different standard Rack Mount Panel configurations as displayed below. Other configurations are available on special order.

**Standard configurations for MicroPak Rack Mount Panels.**

The 23 standard configurations are shown to the right. Included are two blank panels in one- and two-rack unit heights. Mounting capacity ranges from as few as one enclosure of any size to as many as 20 N1 enclosures mounted vertically.

Space permitting, the blank panels may be customized to mount any combination of MicroPak Enclosures and/or other components. For details on customizing, please refer to pages 20-21.

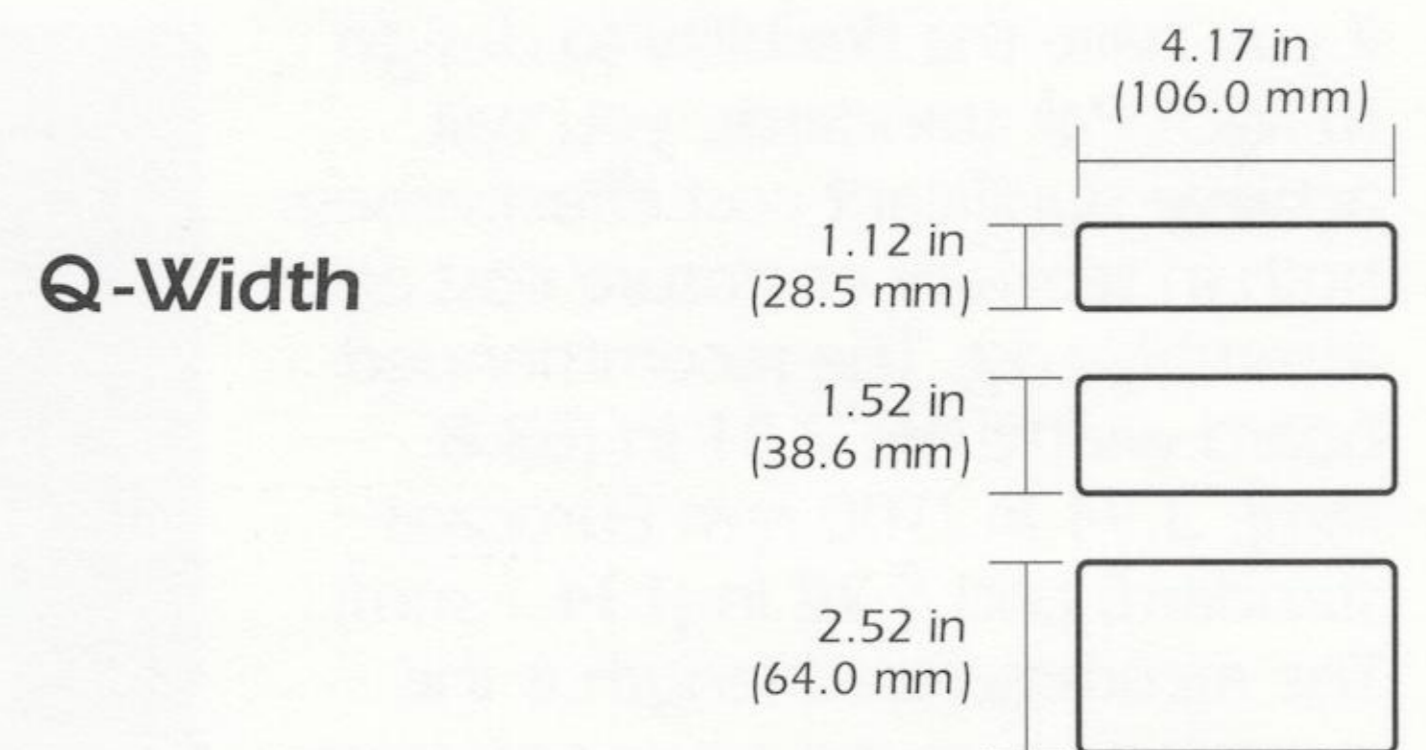
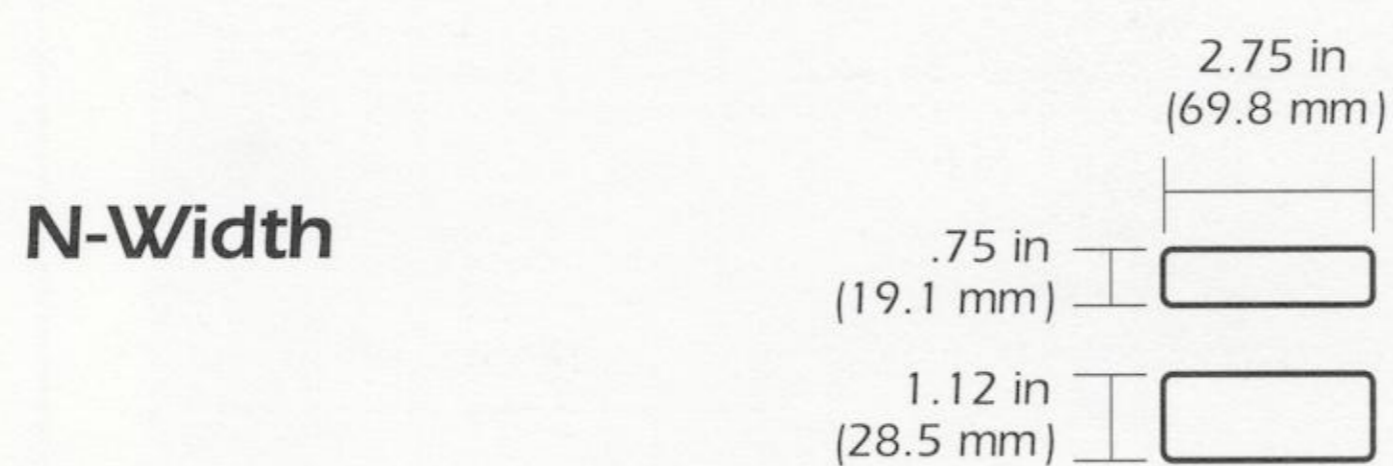

**N1 Configurations**

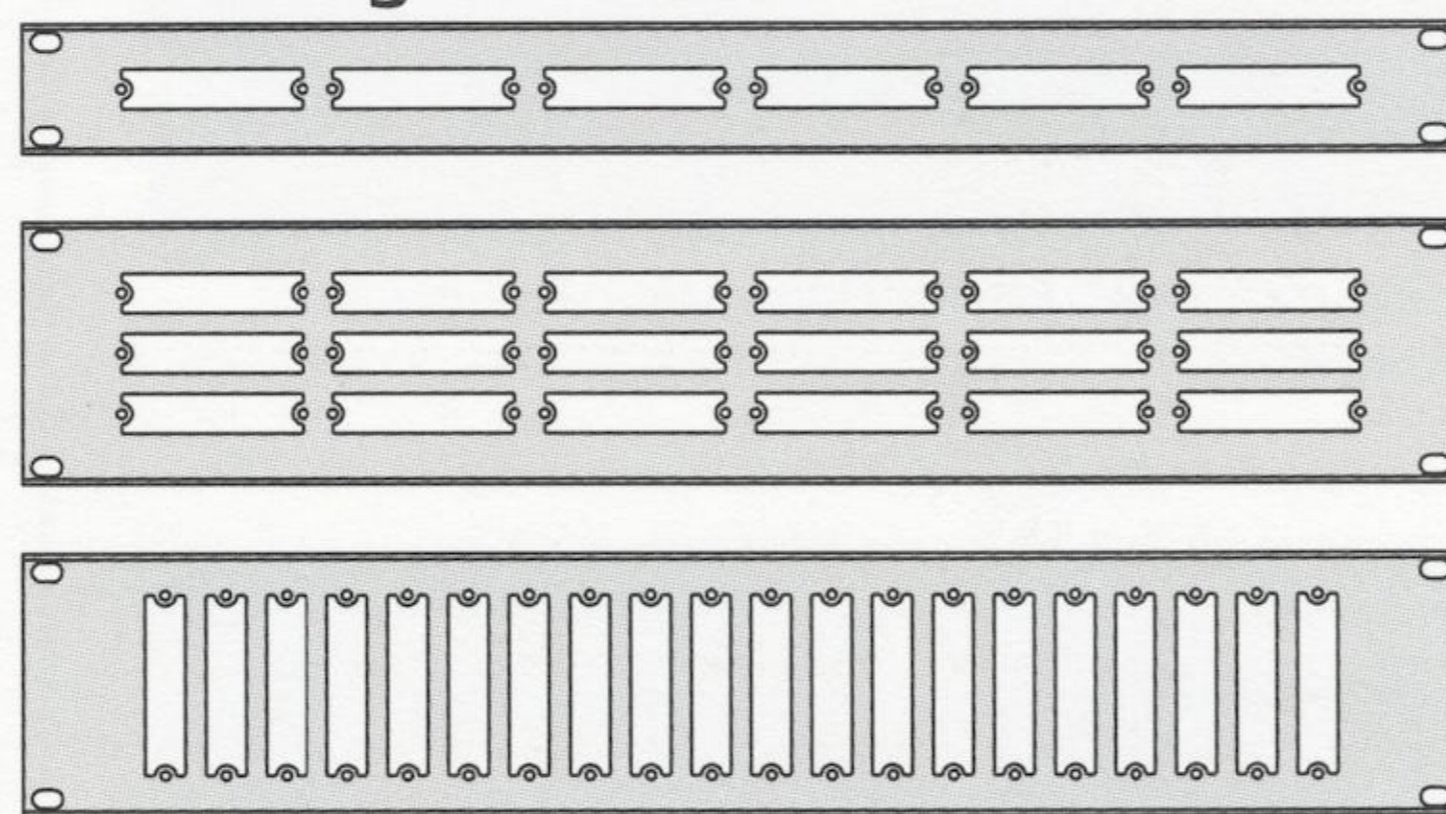

**N2 Configurations**

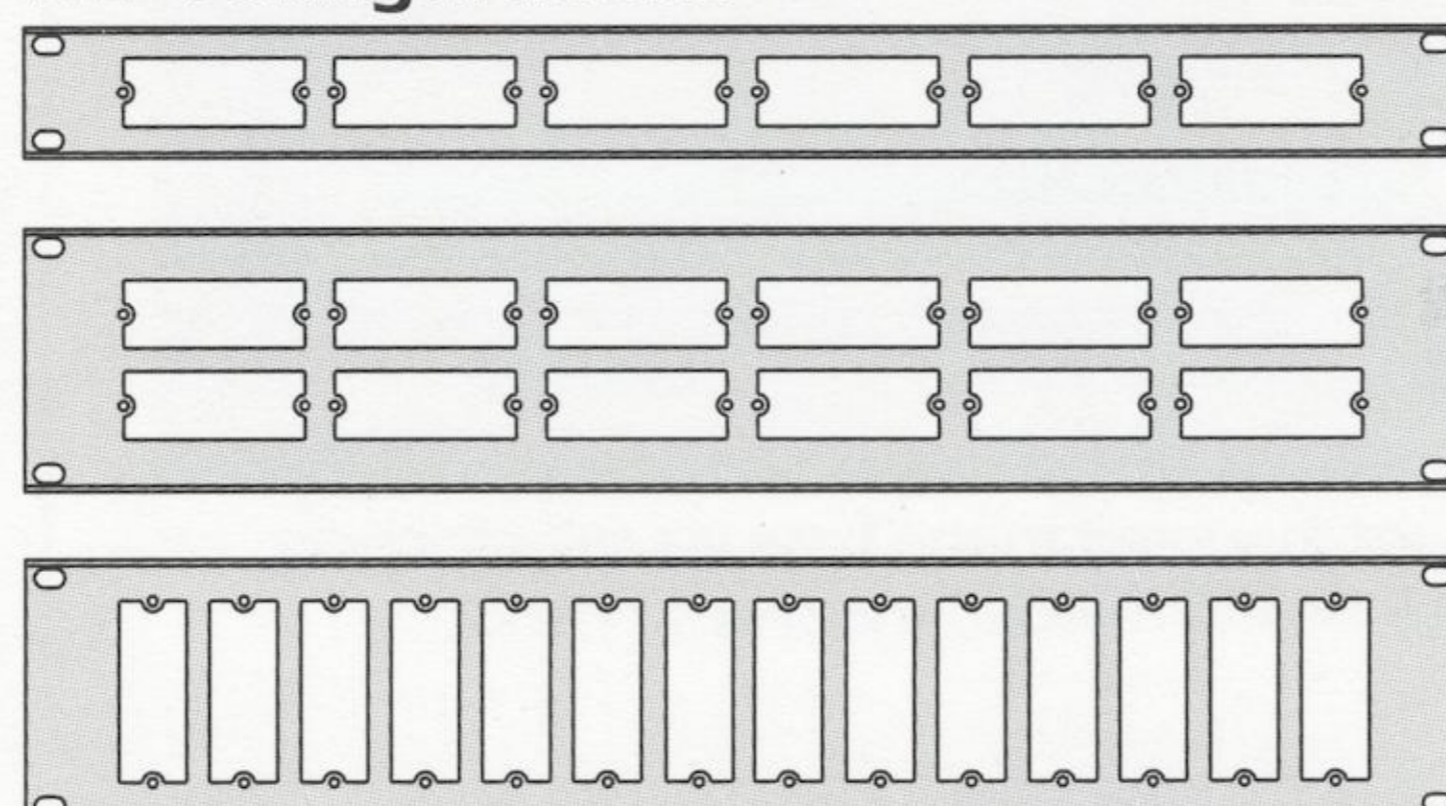

**Q0 Configurations**

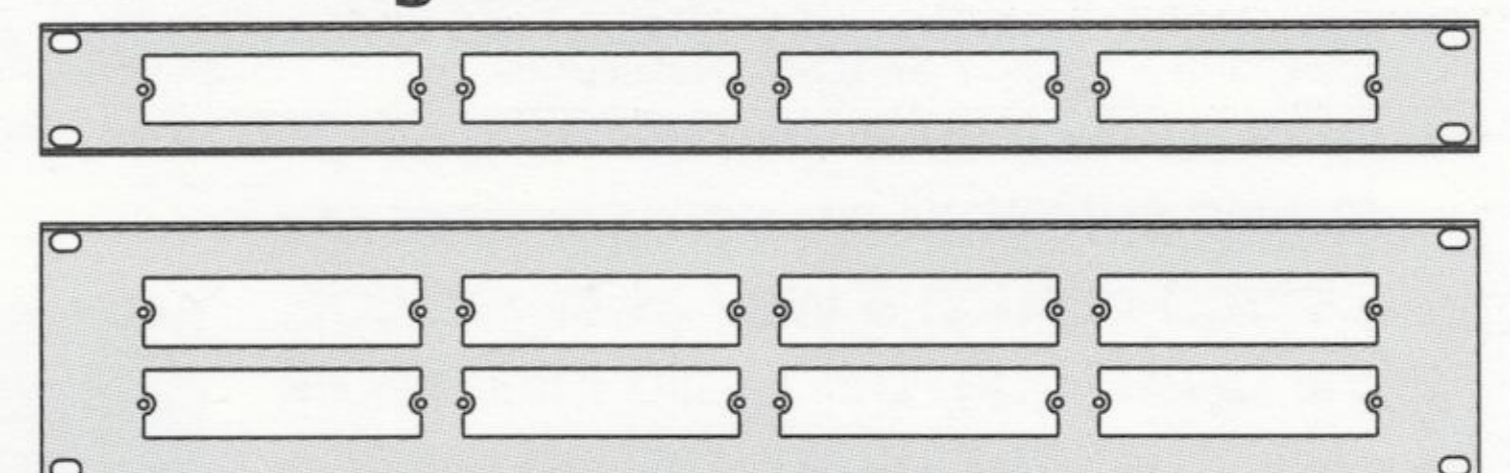

**Q1 Configurations**

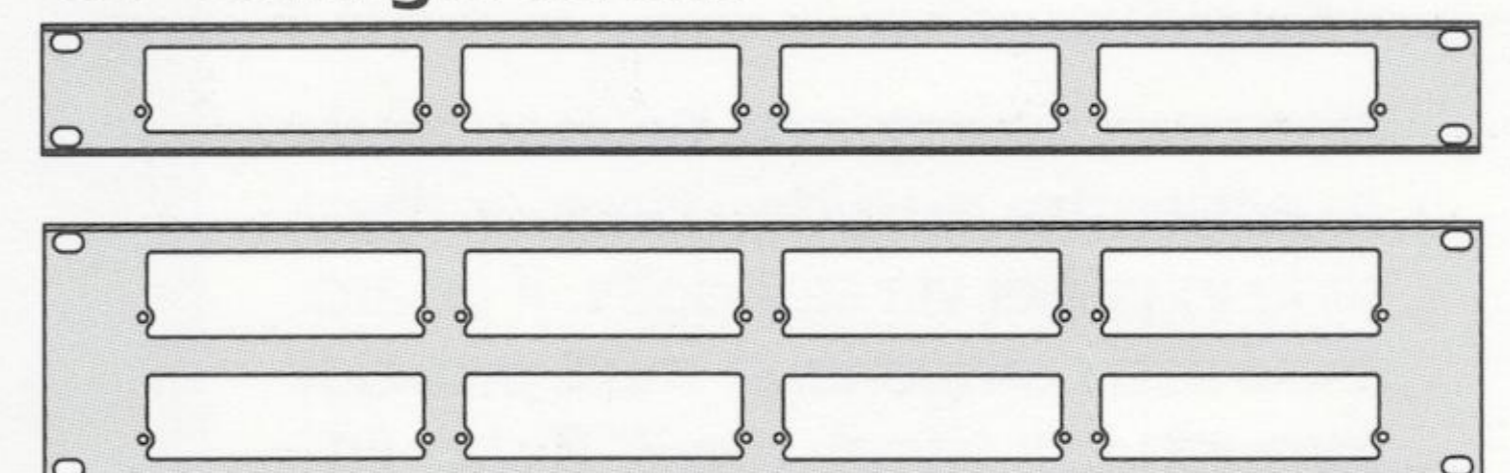

**Q2 Configuration**

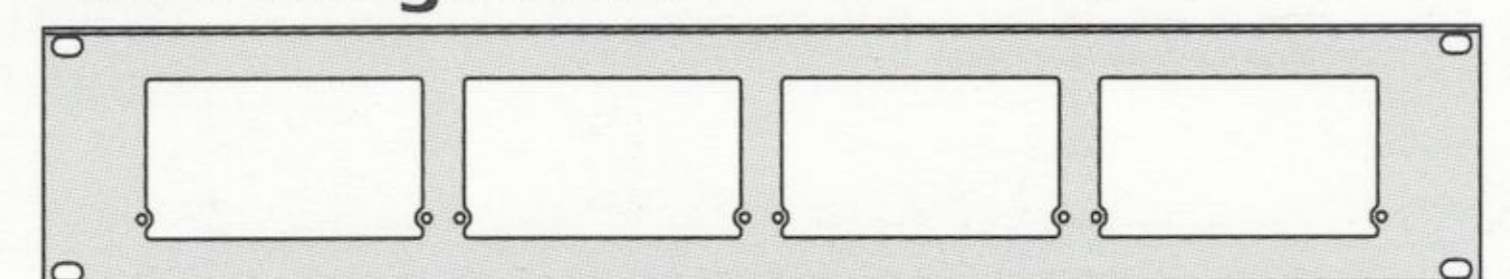

## Typical Mounting Configuration

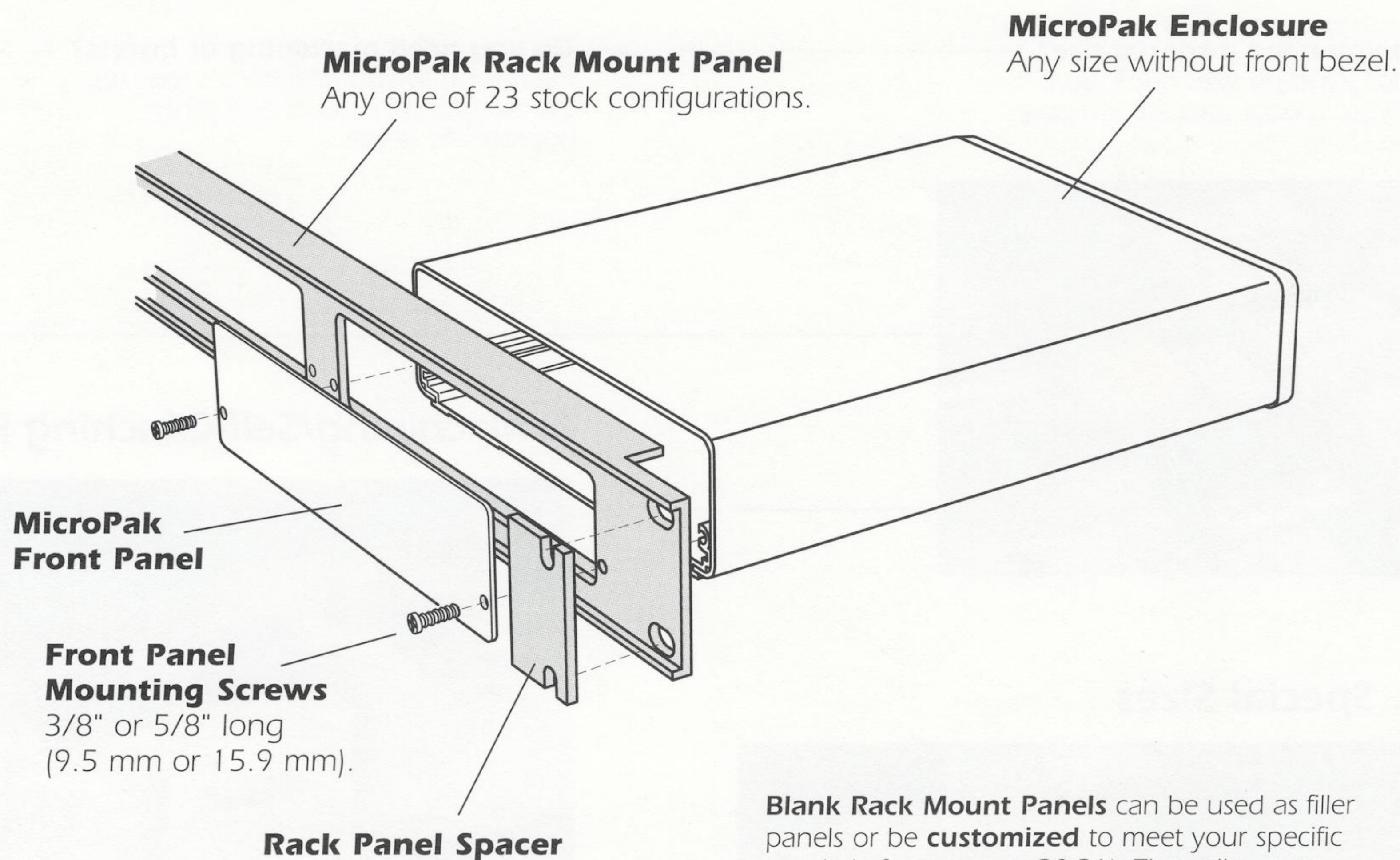

**Blank Rack Mount Panels** can be used as filler panels or be **customized** to meet your specific needs (refer to pages 20-21). They allow you a convenient way to interface your MicroPak Enclosure with other electronics or even with another MicroPak of a different size.

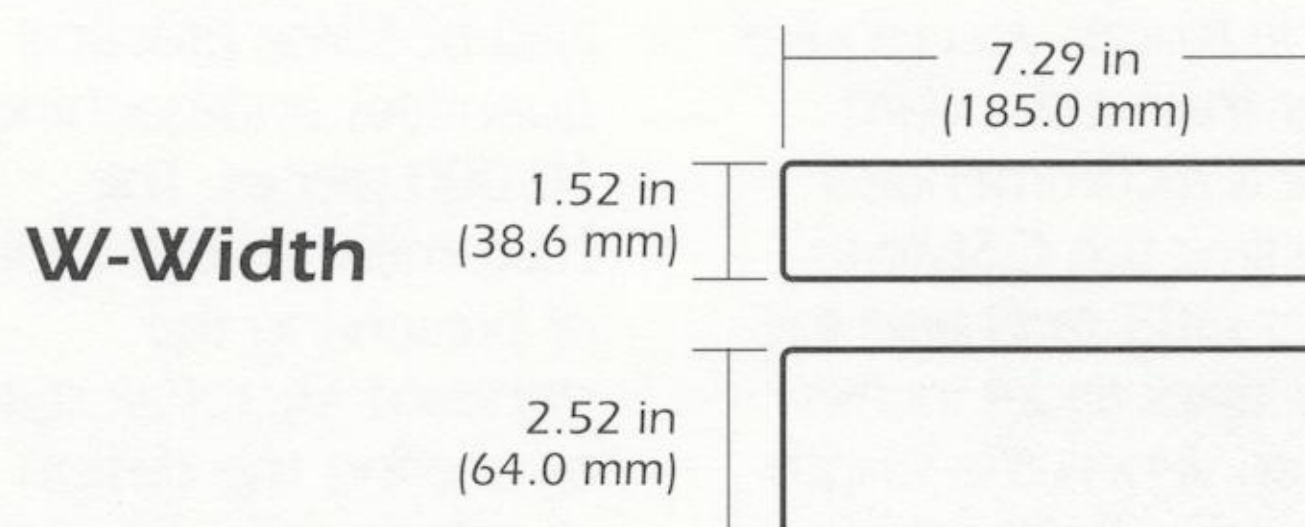
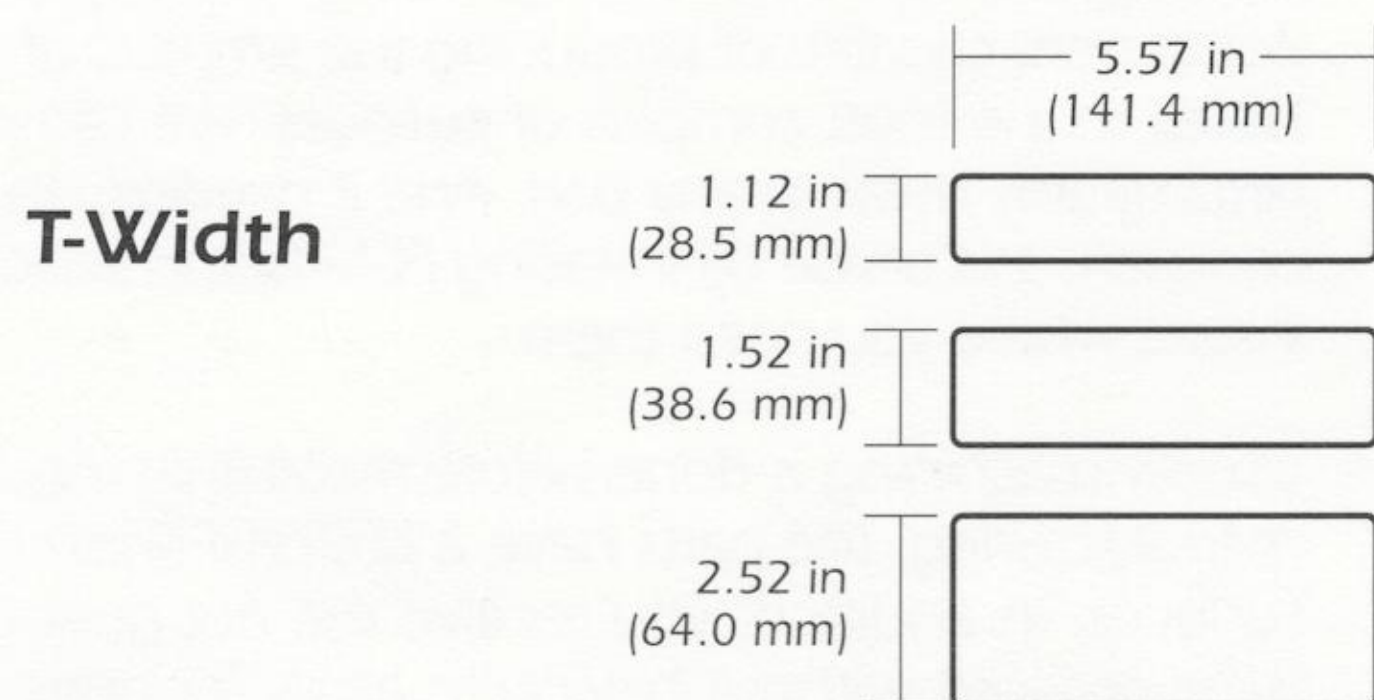
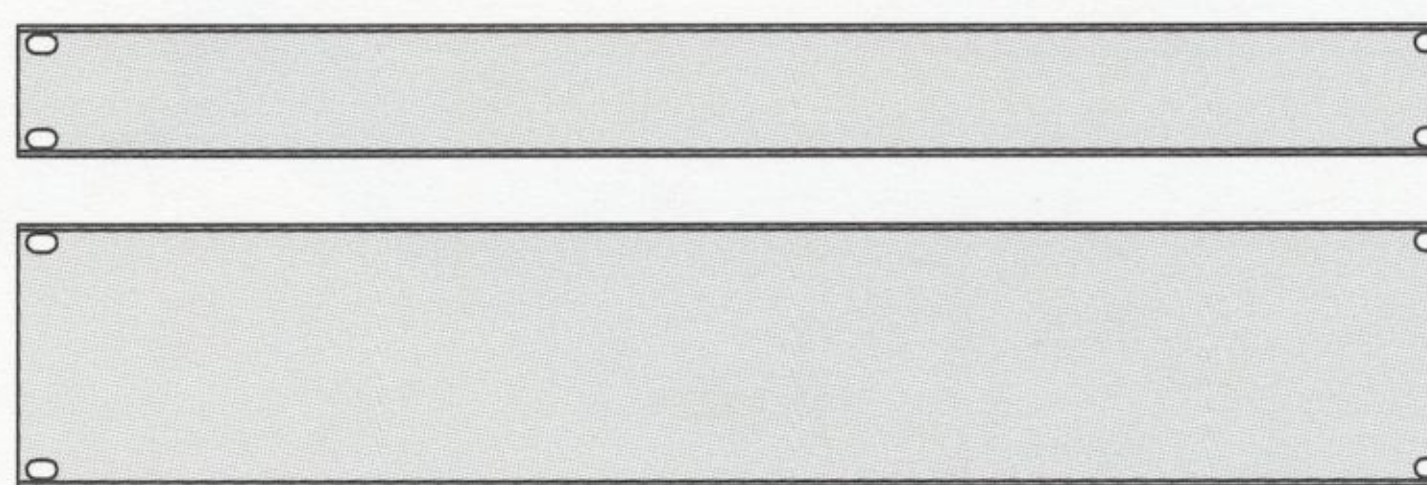

### T0 Configurations

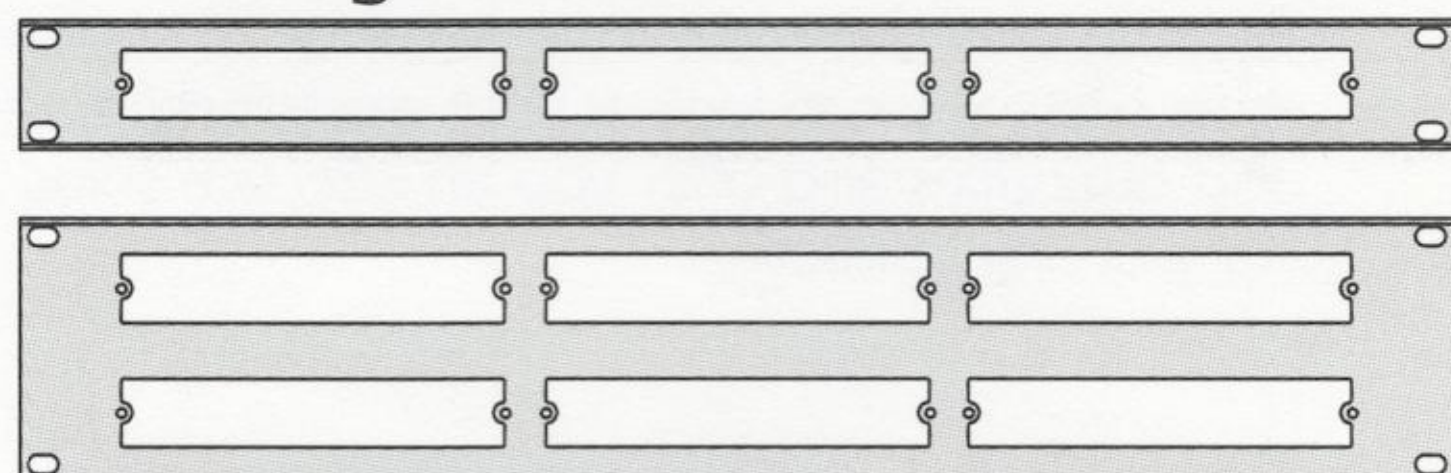

### T1 Configurations

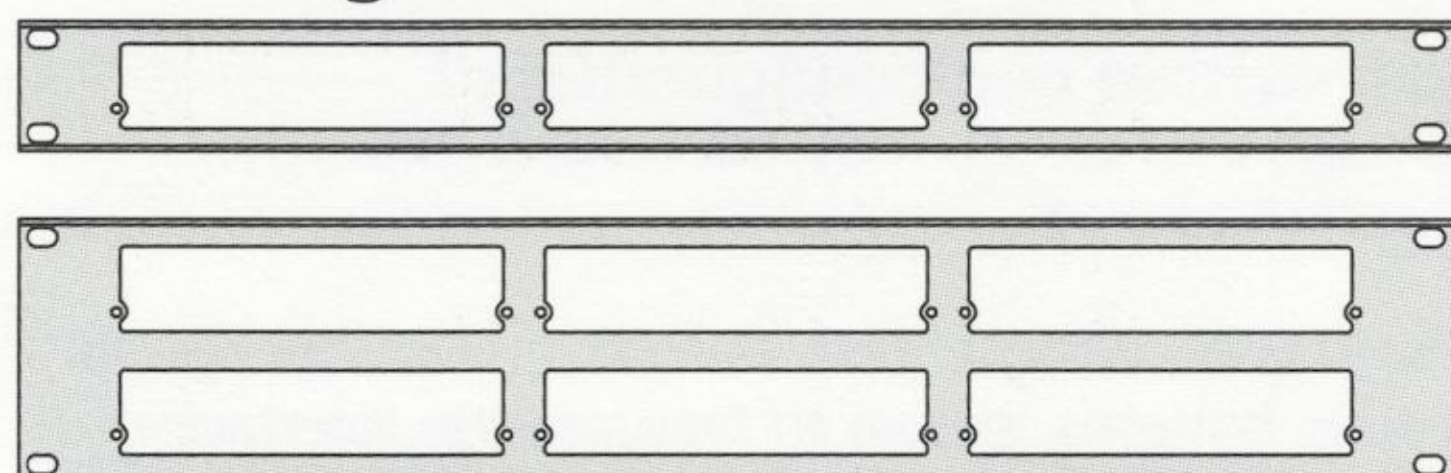

### T2 Configuration

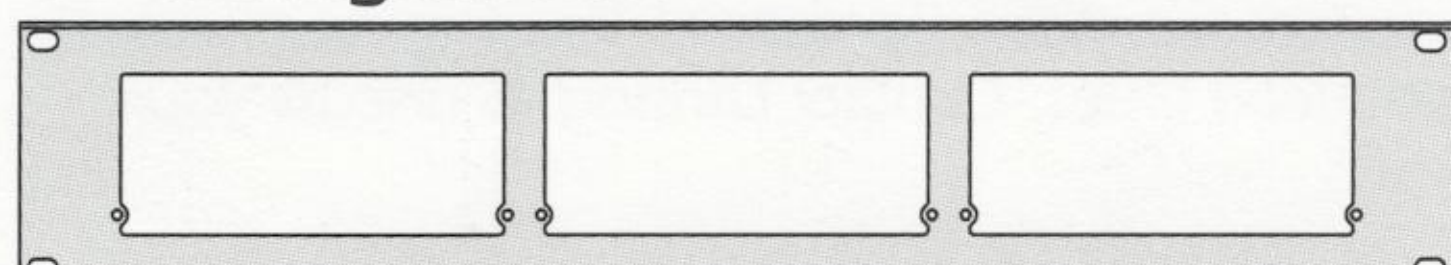

### W1 Configurations

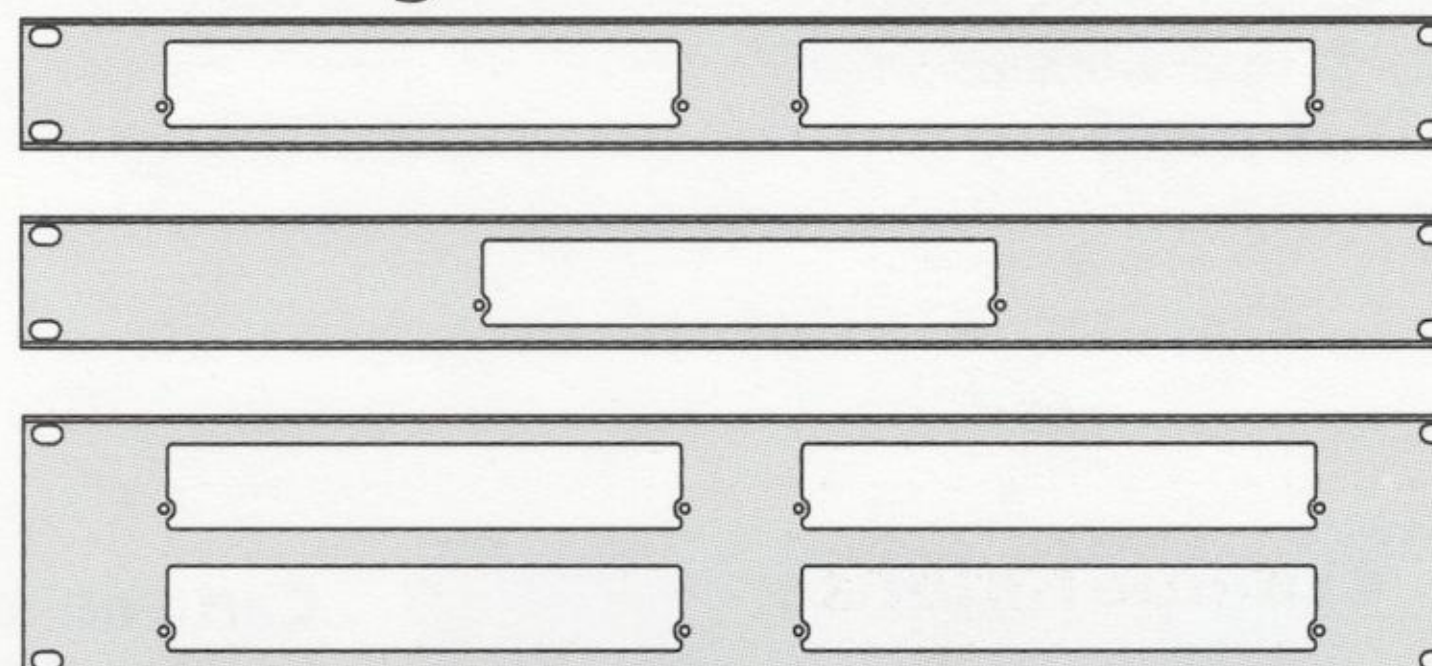

### W2 Configurations

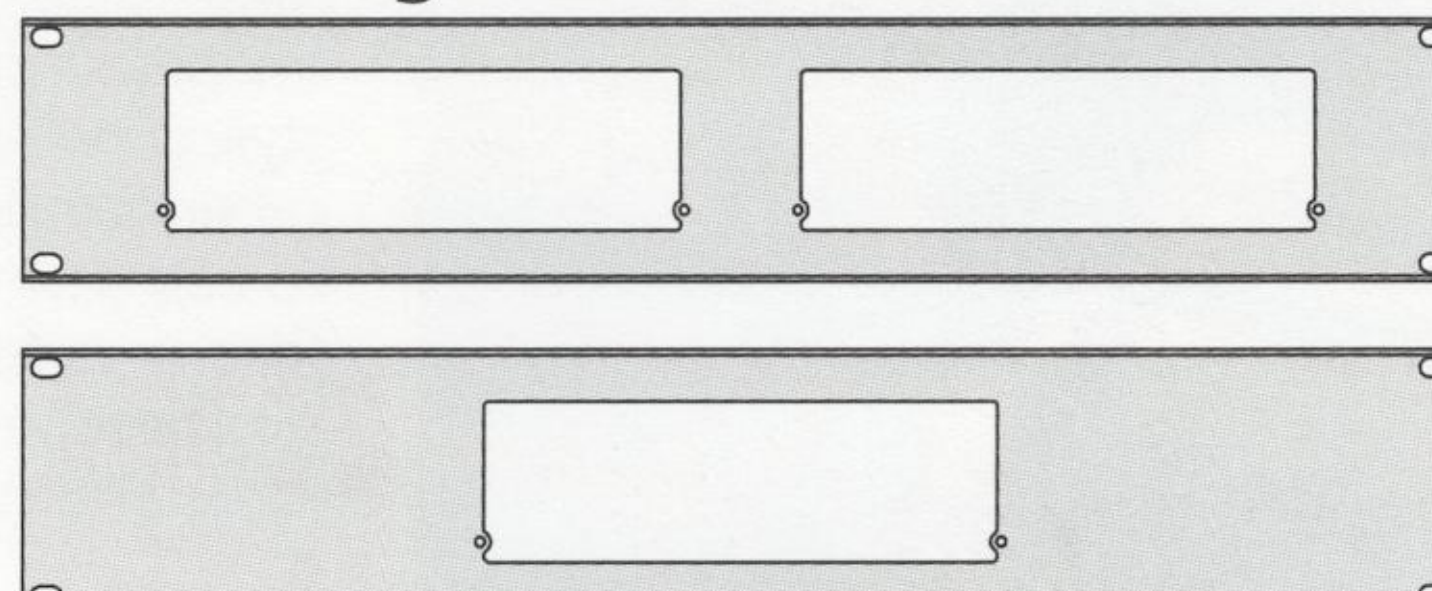

**Customization**  
(see pages 20-21)  
Find out what you can do to have us make a MicroPak distinctly yours.



### MicroPak Rack Mount Panel Technical Data (inserted under back flap)

Find specifications, engineering drawings and other technical details. Reference page 8 in all 3 tech data sheets.



**Price List**  
(inserted under back flap)  
Find MicroPak Rack Mount Panel prices.

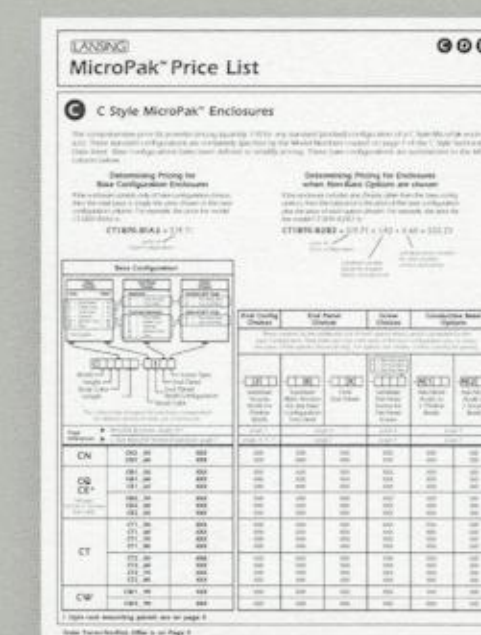

**Order Form/Sample Offer**  
Place an order or purchase a sample MicroPak at a special introductory no-risk offer price.

**Technical Support**  
(see page 22)  
Learn how our experienced staff can answer your technical questions.

# Customization

Finishing the job...making a MicroPak part of your product

## LEVEL 1 ►

A variety of custom options including special dimensions, machining and graphics allows MicroPak to take on a personality that's all yours. And Lansing is uniquely qualified to do it for you. Our experienced staff can provide the customizing details you need and deliver quality results at a reasonable cost.



**Do you need a special size?**  
If our standard sizes don't work for you, special sizes are available.

**Do you need machining or inserts?**  
Interfacing to your electronics requires the addition of cutouts and other appropriate details.

### Why you should want Lansing to do your customization:

- Nobody knows our product better than we do.
- Experience. It's an everyday part of our business.
- Extensive inventory of machinery, fixturing and tooling. Includes proprietary equipment for working with extrusions.
- Multiple ways of manufacturing most parts – we can select the most appropriate.
- High quality consistent with the basic MicroPak. Finish goes on after machining.
- Fast delivery. 15 to 23 working days.
- We keep our delivery promises.
- Reasonable pricing.
- You get the quantity you order. No losses. No overruns.
- Option of scheduled releases.
- You get efficiency of one-stop shopping (single source).

## 1. Special Sizes



The **length** (front to back) dimension of any MicroPak Enclosure is easily varied. When the length you require is greater than a standard length, it is recommended that you limit the C Style to 15 inches (385 mm) and the D and E Styles to 24 inches (610 mm). When the length you require is shorter than the standard length, material savings can offset setup costs in quantities as small as 10-25 pieces.

Changes to **height** and **width** will require significant tooling costs and become practical in quantities approaching 10,000 pieces. The customer has the choice of preserving the standard MicroPak styling or altering the design details in order to create a unique appearance.

## 2. Machining/Self-Clinching Inserts

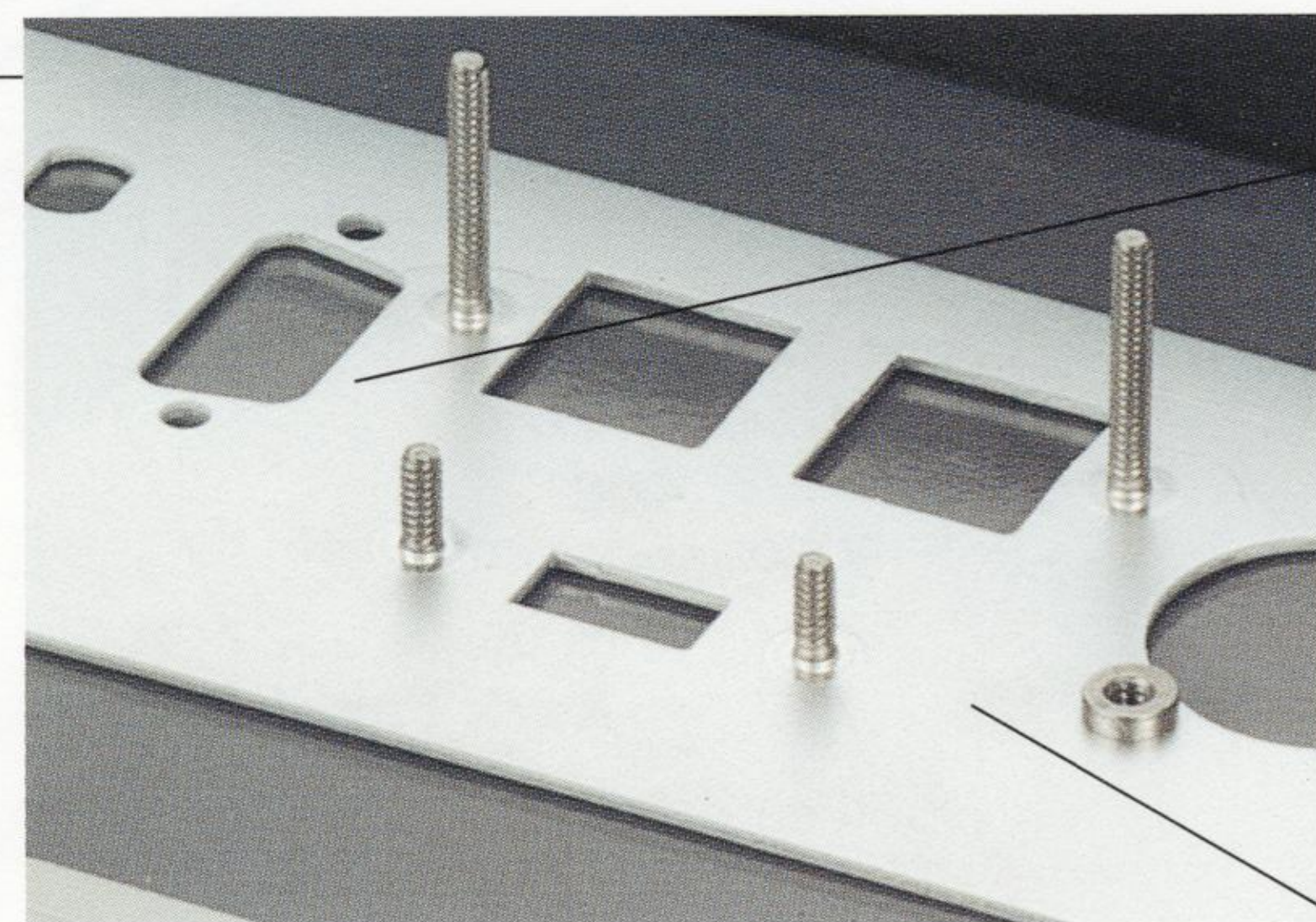

Interfacing your electronics with your choice of enclosure requires the addition of mechanical features. Whether those features require **machining** or the installation of **self-clinching inserts** to the enclosure, Lansing is well equipped and organized to satisfy your needs in a timely fashion and at a reasonable price.

Lansing has dedicated drilling, milling and punching equipment capable of producing the simplest of round **holes** to the most complex of **cutouts**. We can machine virtually any detail in any part. And if needed, we can complete this phase by installing PEM brand self-clinching inserts where you need them.

Usually machining is done before metal finishing. After manufacturing, the parts have a uniform finish on all surfaces. In addition, you receive the net quantity you have ordered without having to allow for parts lost in production setup and scrap.

Because we have more than one way to customize most parts, we can look at your machining requirements and quantities and offer you an effective solution – not just any solution.

## LEVEL 2 ►

Your application may benefit, functionally and/or financially, from higher levels of customization – optimized extrusions, custom-molded parts, special end configurations and even new designs.

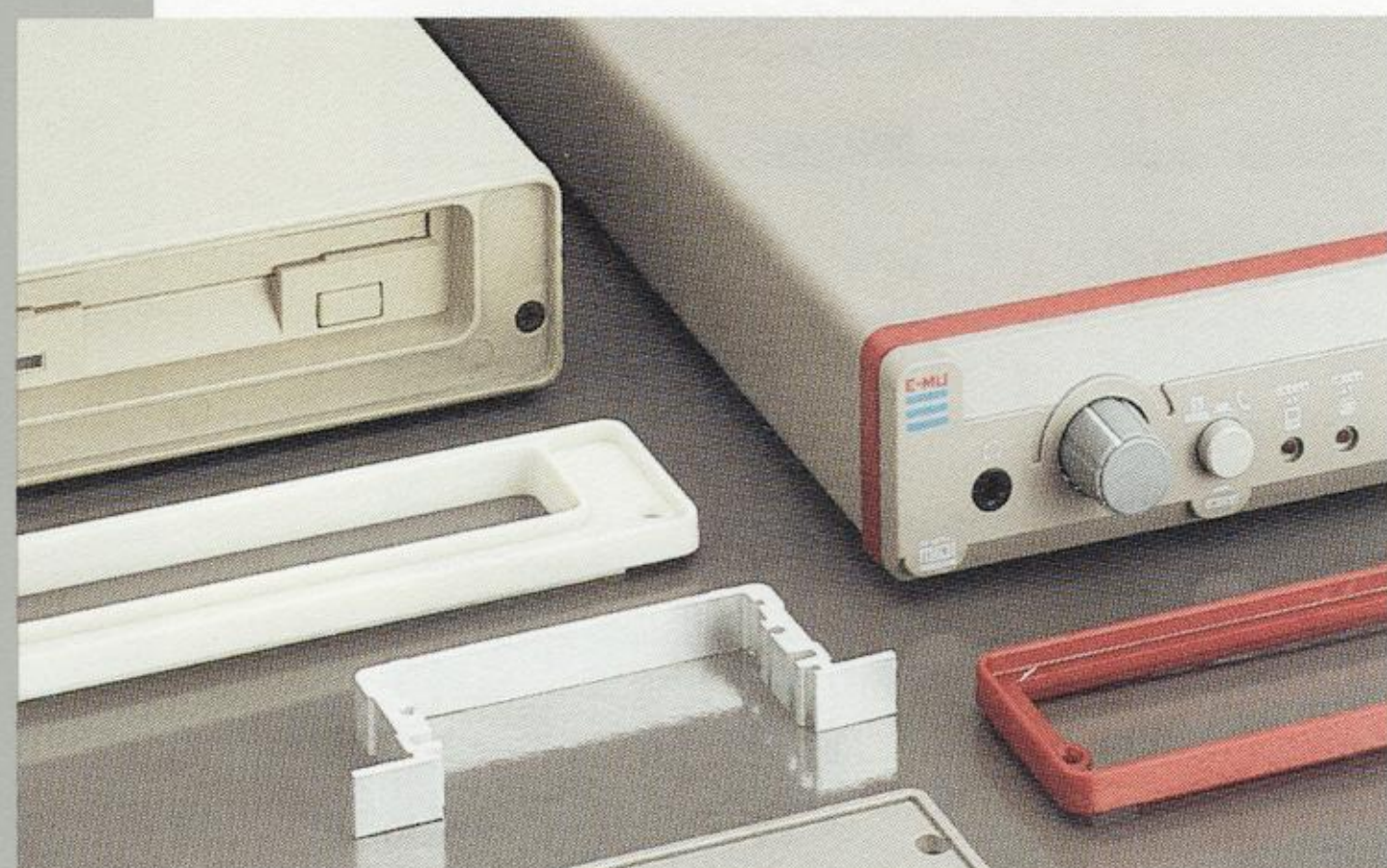

**Can you benefit from custom end configurations?**  
Custom designed end caps and bezels may offer significant advantages – including cost savings.

Imagine a custom-molded end configuration. Perhaps it includes special styling details, custom hole patterns, details to facilitate the interfacing of other components or even molded-in graphics – all factors that contribute to cost savings by combining multiple parts into one, minimizing assembly time or reducing the need for secondary operations. You may be pleasantly surprised at the cost and lead times. Contact Lansing to discuss your ideas and needs.

**Do you need graphics...special finishes, colors or materials?**  
Your product isn't complete until your name and your graphics go on it – either by silkscreening or through the application of overlays. You may also require special finishes, colors and materials.

### 3. Graphics/Special Finishes, Colors and Materials

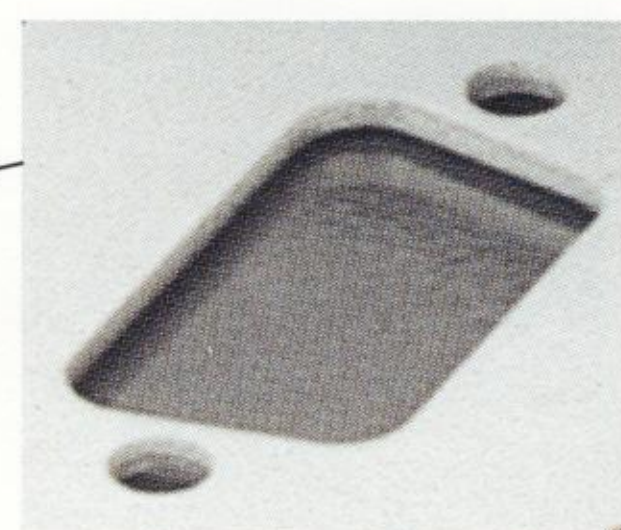

**Machining**  
Cutouts of virtually any shape.

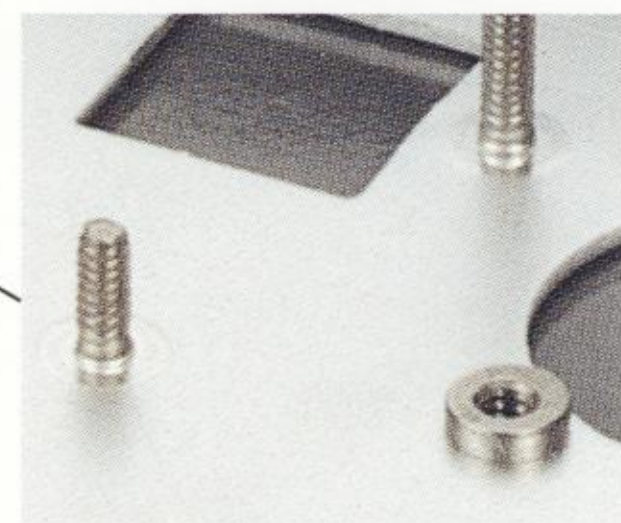

**Self-Clinching Inserts**  
Captive nuts, standoffs or studs.



**Holes**  
Round or D-shaped. Plain, countersunk or counterbored.



Beginning with camera-ready artwork, provided by you or created by us, Lansing can **silkscreen** any MicroPak part except the bezel. The cost of one-color silkscreening is reasonable even in small quantities.

**Overlays** are a particularly elegant solution that, more than any other single element, allows your MicroPak to take on a distinctive appearance. Lansing can assist you with the design and specification of graphic overlays for your product. Although we do not manufacture overlays, we'd be happy to refer you to reputable vendors who do, some of whom have tooling available for the blanking of all sizes of MicroPak panels. Overlays can be shipped to Lansing for application and secondary mechanical operations. They become cost effective in the 250 -1000 piece range depending on the number of colors involved.

For those who require **special colors**, Lansing is prepared to work with you whether it requires painting, custom vinyls or molding in custom colors. The practicality of some options depends on quantity.

The standard MicroPak materials and finishes have been specified carefully, but may not be appropriate for all applications. **Special finishes**, both conductive and non-conductive, can be specified for most parts. **Special materials** can also be specified. Vinyl-clad aluminum can be used in place of the standard vinyl-clad steel covers. Bezels and end caps can be molded in a variety of plastics.



**Silkscreening**  
Available in one or more colors



**Overlays**  
High-impact graphics



**Special Colors**  
Meet company standards



**Special Finishes**  
Satisfy shielding requirements

**The quotation process:**

*Informal estimate: Call. We'll give you a realistic estimate based on your description. When appropriate, we'll offer alternatives you may not have considered.*

*Formal quote: Provide us with sketches (formal drawings not necessary) that accurately identify hole sizes. We will submit in writing a quote that itemizes on a part-by-part basis the cost of Non-Recurring Tooling, Setup and Unit Price for all major operations (machining, painting, silkscreening, etc.).*

*NR Tooling is a one-time charge (assuming no design changes). Most of the time, setup charges are applied once, but this may vary depending on commitment and release schedule. Unit price is usually independent of quantity.*

**The standard manufacturing process:**

- Assign Lansing part number to every part requiring customization. Cross reference to customer part number.
- We create a drawing that will control manufacturing and inspection.
- Drawings are submitted by fax for customer approval.
- Once approved, manufacturing begins using the most appropriate equipment (CNC mill, punch, CNC punch, etc.).
- Metal finishing is done after machining.
- Self-clinching inserts are installed if required.
- Silkscreening or other secondary operations are done.
- Inspection to approved drawings.
- Packaged for complete or scheduled shipments.

**Expediting:**

*Standard lead times are 15-23 working days depending on quantity, complexity and finishing. If faster delivery is required, we try to accommodate your need within our normal manufacturing schedule. If time is too short, we may be able to provide expedited delivery at a premium price.*

**Can you benefit from a custom tube design?**

Special extrusion details, internal or external, may enhance the MicroPak concept for your application.

Imagine an external mounting flange that allows direct wall mounting or interfacing to other electronics... or even cooling fins. Consider an internal detail that locates a printed circuit board exactly where you need it...or securely mounts a disk drive or other components. Any of these are practical and potentially time- and cost-saving features. Contact Lansing to discuss your needs.

**Do you need even more?**

Lansing can work with you to realize a new design.

Lansing Enclosure designs have originated from real customer needs. We have an extensive experience base we are willing to share with you in an effort to find new designs that directly address your requirements. We look forward to a candid discussion of your needs and the appropriateness of Lansing working to meet them.